



Stair Parts

Fitts ™
Manufacturers of Quality Stair Parts

More Than a Half Century of Quality, Service & People



Frank Fitts, Jr. Circa 1947

For more than a half century, the Fitts' name has been associated with quality in the woodworking industry.

Founded in 1947, in Tuscaloosa, Alabama, Frank Fitts, Jr., initiated a standard of fine craftsmanship and quality service as a manufacturer of precision wood components. His talents as a woodsmith and his dedication to principle became a strong foundation for what Fitts Industries, Inc. has become today.

More than 50 years later the current Fitts family operates on those same principles manufacturing some of the finest stair parts on the market.

Our success is based on a vertically integrated structure that includes: the process and storage of green lumber, on site kiln drying operations, state-of-the-art compu-rip operation, lathe and moulder operations and East Coast and West Coast warehousing facilities that effectively supply our customers.

Fitts Industries' mission is to be a world leader in the wood products industry. By committing to people, technology, and a never-ending process of improvement, we will provide our customers the highest level of quality and service.

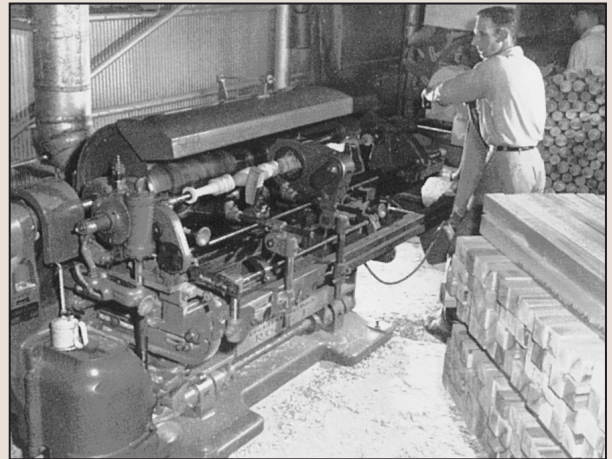

Fitts Industries Lathe Department Circa 1948

Lewis Fitts

Frank Fitts III

Fitts

Contents

The Basics	2-3
Hemlock Quick Reference	4-5
Hardwood Quick Reference	6-7
Wrought Iron Quick Reference	8-9
Hemlock Traditional Over-the-Post & Post-to-Post	12-13
Hemlock Hampton Post-to-Post	14
Hemlock Olympia Post-to-Post	15
Hemlock Madison Post-to-Post	16
Hemlock Mission Style Post-to-Post	17
Hemlock Fittings	18-20
Hemlock Treads, Risers & Starting Steps	21
Knotty Pine	22
Hardwood Lexington Post-to-Post & Over-the-Post	24-25
Hardwood Hampton Post-to-Post & Over-the-Post	26-27
Hardwood Traditional Post-to-Post & Over-the-Post	28
Hardwood Mission Style Post-to-Post & Over-the-Post	29
Hardwood Mini-Canterbury Post-to-Post & Over-the-Post	30-31
Hardwood Canterbury Post-to-Post & Over-the-Post	32-33
Hardwood Fittings	34-36
Hardwood Treads, Risers, & Starting Steps	37
Hardwood Treads, Risers, & Accessories	38-39
Wrought Iron Product Finishes	42
Wrought Iron Stair Parts	44-45
Wrought Iron Quick Installation	46
Wrought Iron Newels, Shoes, Knuckles & Handrail	47
Stair Take-off Quick Reference	48
Newel Selection	49
Baluster Selection	50
Fitting Selection	51
Hemlock Baluster Length Structure Charts	52-54
Hardwood Baluster Length Structure Charts	55-57
Gallery	59
Wood Species	Inside Back Cover

The Basics

Stairs are often one of the most architecturally significant features of the home, and at the same time one of the most difficult features to design. For the novice or the beginner, there are several things to take into consideration when choosing the correct stair system for your home:

- Is the stair "Post-to-Post" or "Over-the-Post"?
- What species of wood will match the consistency of the home?
- Are the stairs carpeted or bare wood?
- What turnings or newel, baluster and handrail profiles match the theme of the home?
- Most importantly – What are the local building codes regarding stairs in your area?

Post-to-Post vs. Over-the-Post

Post-to-Post Stair – Handrail runs between a series of newels.

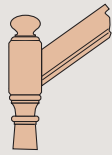

Starting Newel

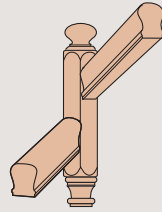

Transitional Newel
Newel w/13" face block

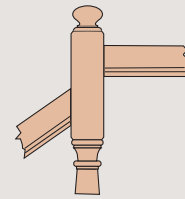

Landing Newel
Newel w/10" face block

Over-the-Post Stair – Handrail runs over a series of newels using a series of fittings. This design provides the aesthetic that the handrail is continuous.

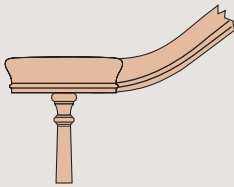

Volute Newel
Volute Fitting

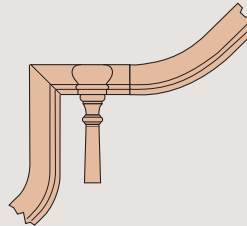

Landing Newel
Gooseneck Fitting

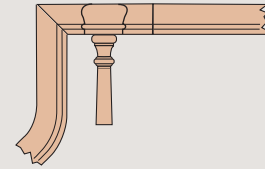

Landing Newel
Gooseneck Fitting

Post-to-Post Stair with Fittings – Handrail runs between a series of newels, but often utilizes gooseneck fittings to make handrail connections, such as changes in rake angle look effortless.

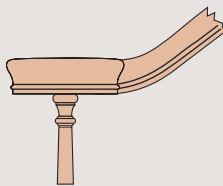

Volute Newel
Volute Fitting

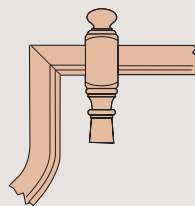

Transitional Newel
Gooseneck Fitting

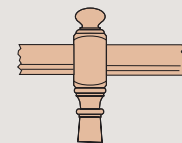

Landing/Balcony
Newel

Post-to-Post & Post-to-Post with Fittings

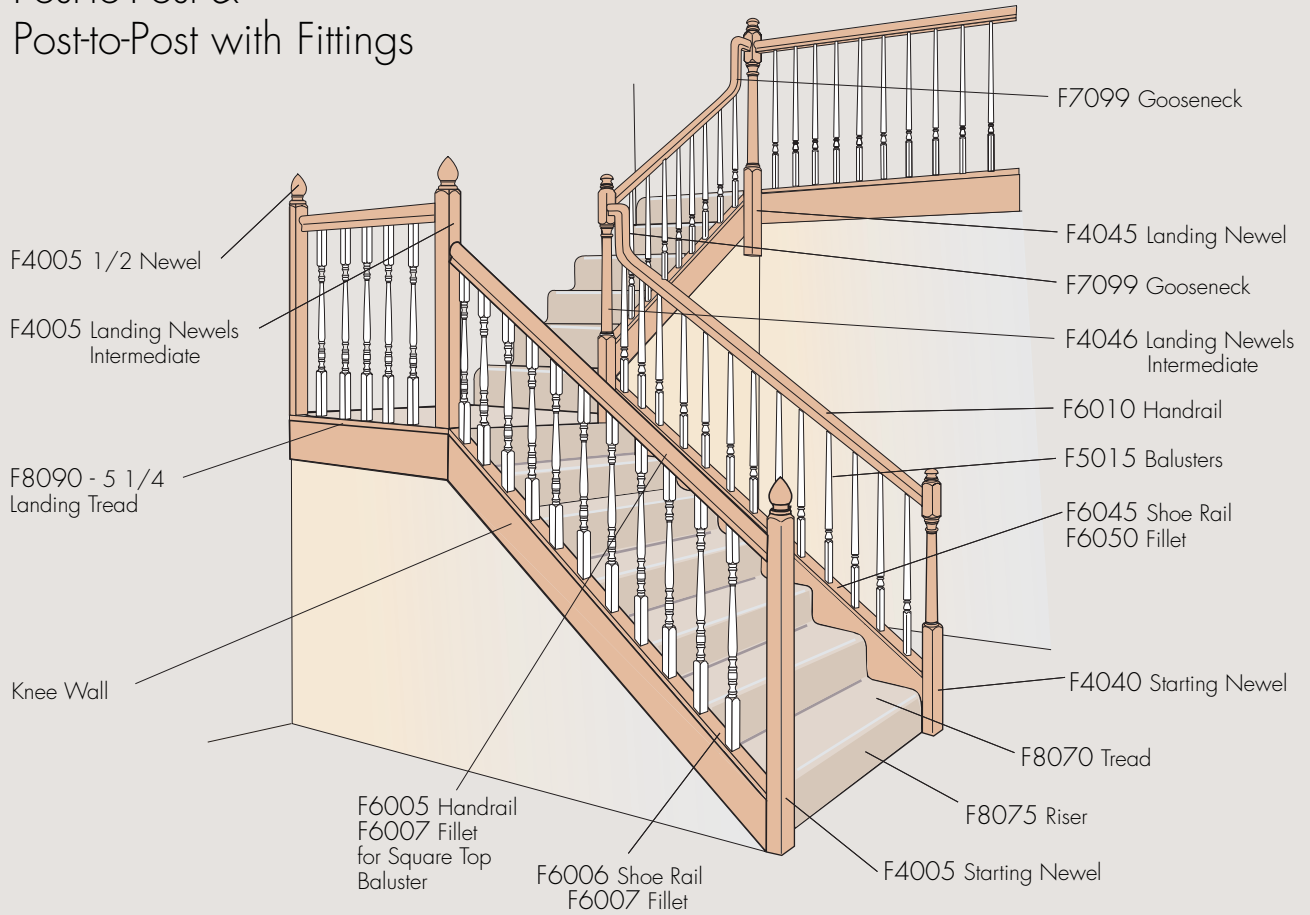

Over-the-Post

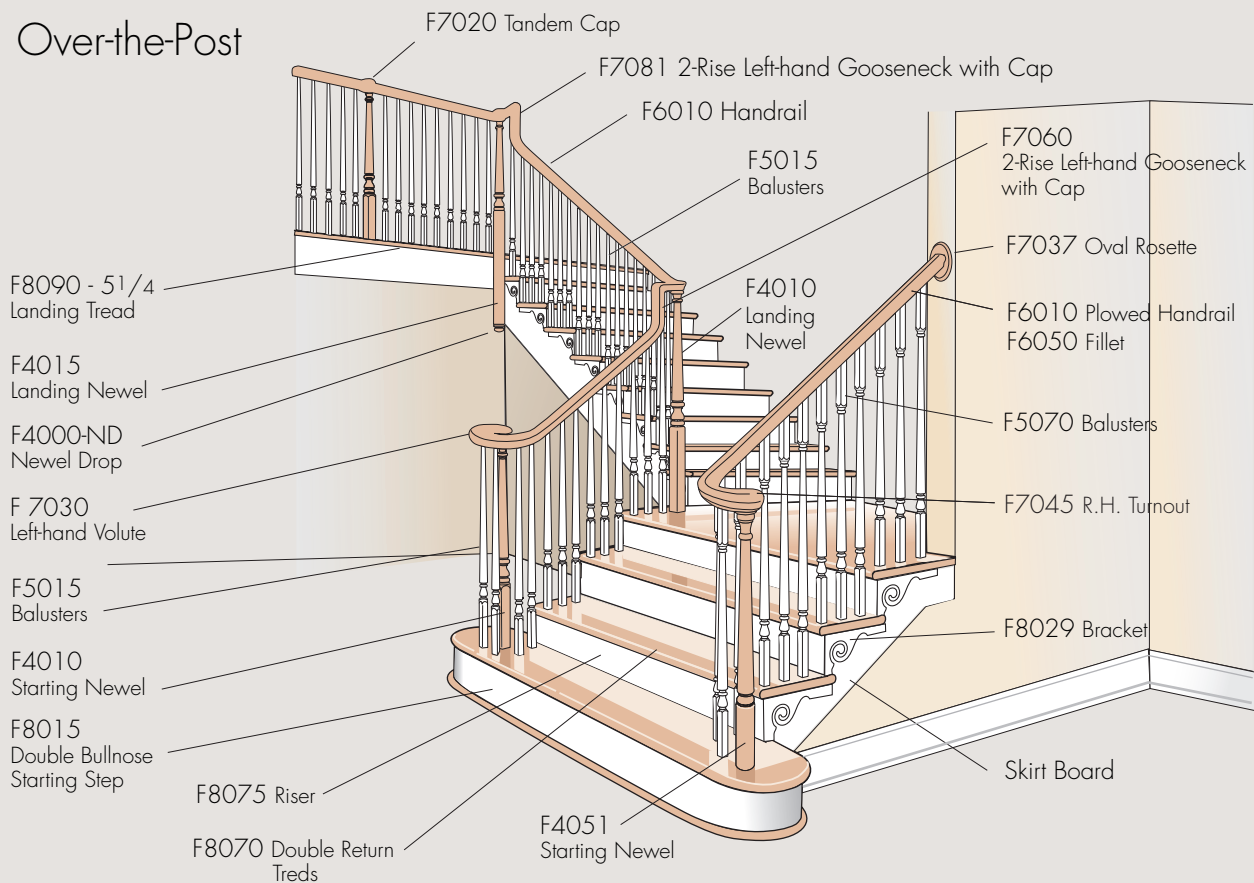

★ Variation in products are used for example only.

Hemlock Quick Reference

Newels Post-to-Post



FH4000-448
Page 17



FH4004
Page 17



FH4005
Page 17



FH4040
Page 13



FH4104
Page 17



FH4204
Page 17



FH3500
Page 16



FH4500
Page 14



FH4840
Page 15

Newels Over-the-Post



FH4010
Page 12



FH4011
Page 12



FH4012
Page 12



FH4013
Page 12



FH4014
Page 12



FH4015
Page 12



FH4018
Page 12



FH4020
Page 12

Hemlock Quick Reference

Balusters



FH5060
Page 17



FH5015
Page 12



FH5015-FL
Pages 12, 13



FH5315
Page 14



FH5610
Page 16



FH5611
Page 14



FH5105
Page 16



FH5050
Pages 12, 13

Balusters



FH5070
Pages 12, 13



FH5360-CH
Page 17



FH5005
Page 14



FH5801
Page 15



FH5802
Page 15

Handrail

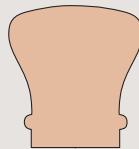

FH6010
Plain/Plowed
Pages 12, 13, 16, 17, 18

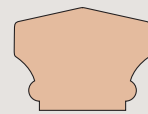

FH6910
Plain/Plowed
Pages 12, 13, 16, 17, 18

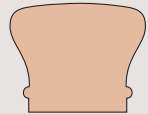

FH6210
Plain/Plowed
Pages 14, 17

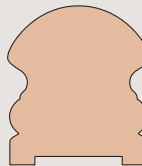

FH6019
Pages 14, 15, 17

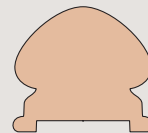

FH6005
Pages 14, 15, 17

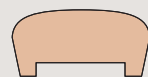

FH6244
Page 15

Hardwood Quick Reference

Newels Post-to-Post



F4040
Page 28



F4140
Page 24



F4940-3-52
Page 30



F4940-FL-3-52
Page 30



F4500
Page 26



F4940-52
Page 32



F4940-FL-52
Page 32

Newels Post-to-Post



F4000
Page 29



F4000-CH
Page 29



F4090
Page 29

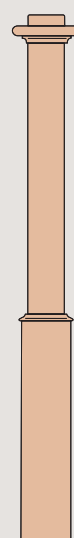

F4091
Page 29

Newels Over-the-Post



F4010-48
Page 25



FH4020
Page 12



F4215
Page 27



F4220
Page 27



F4910-3
Page 31



F4910-FL-3
Page 31

Hardwood Quick Reference

Balusters 1-1/4"

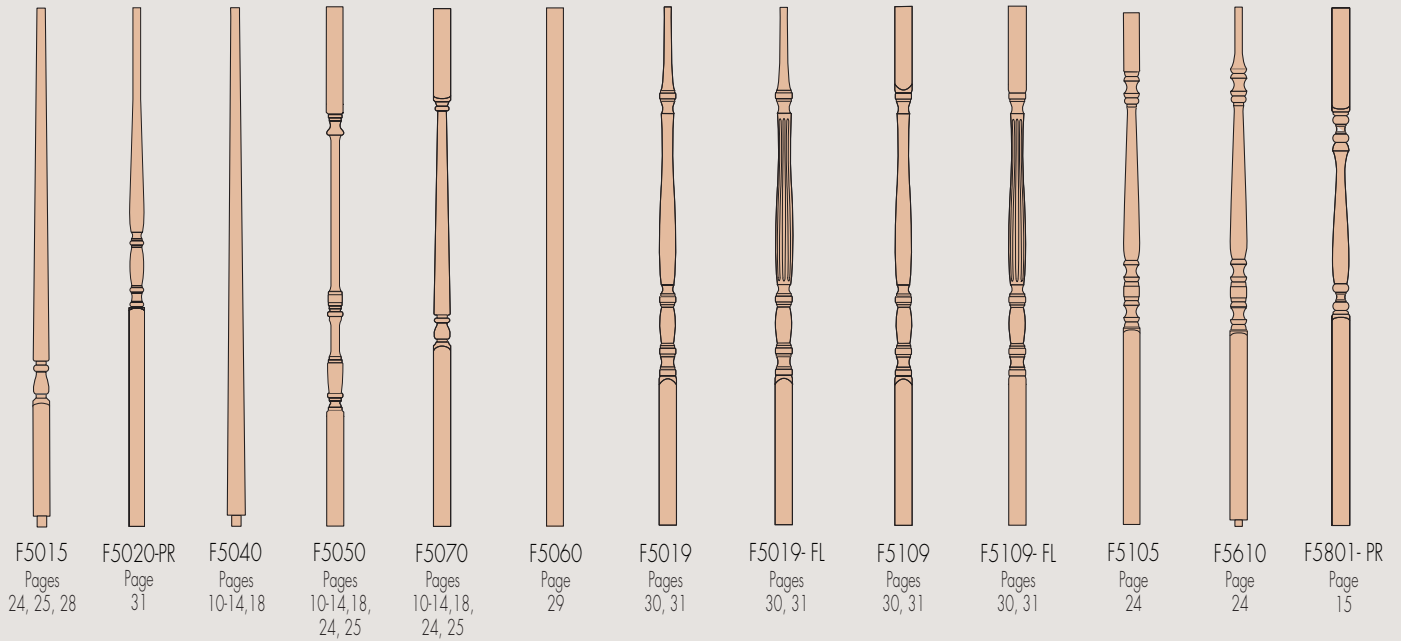

Balusters 1-3/4"

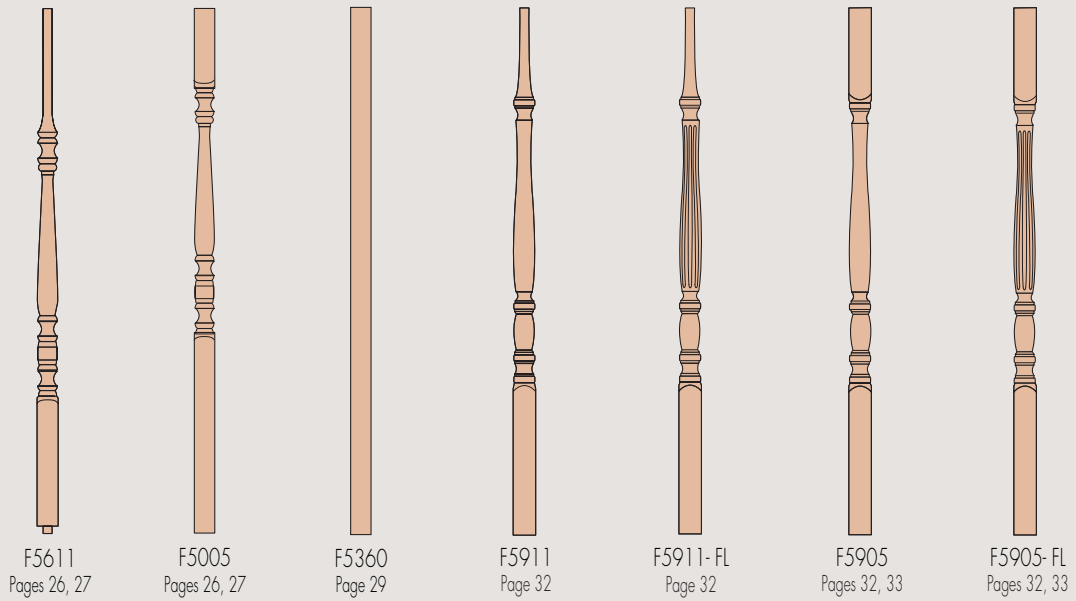

Handrail

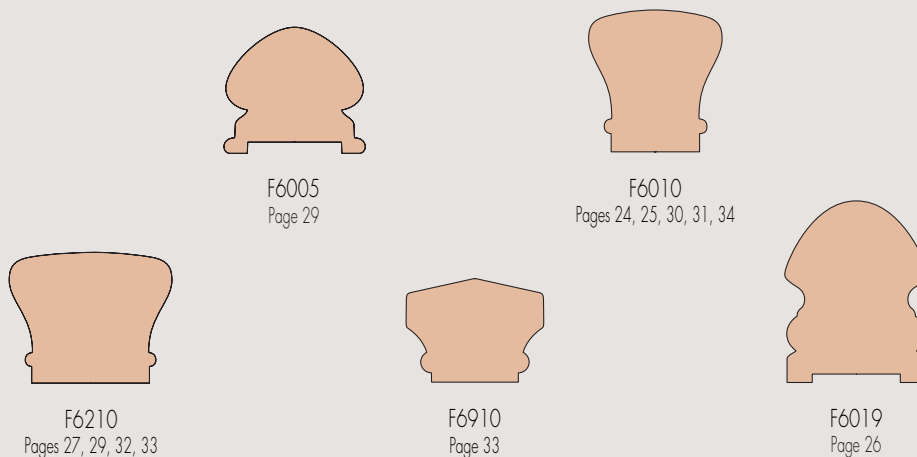

Iron Balusters

1/2 inch Balusters

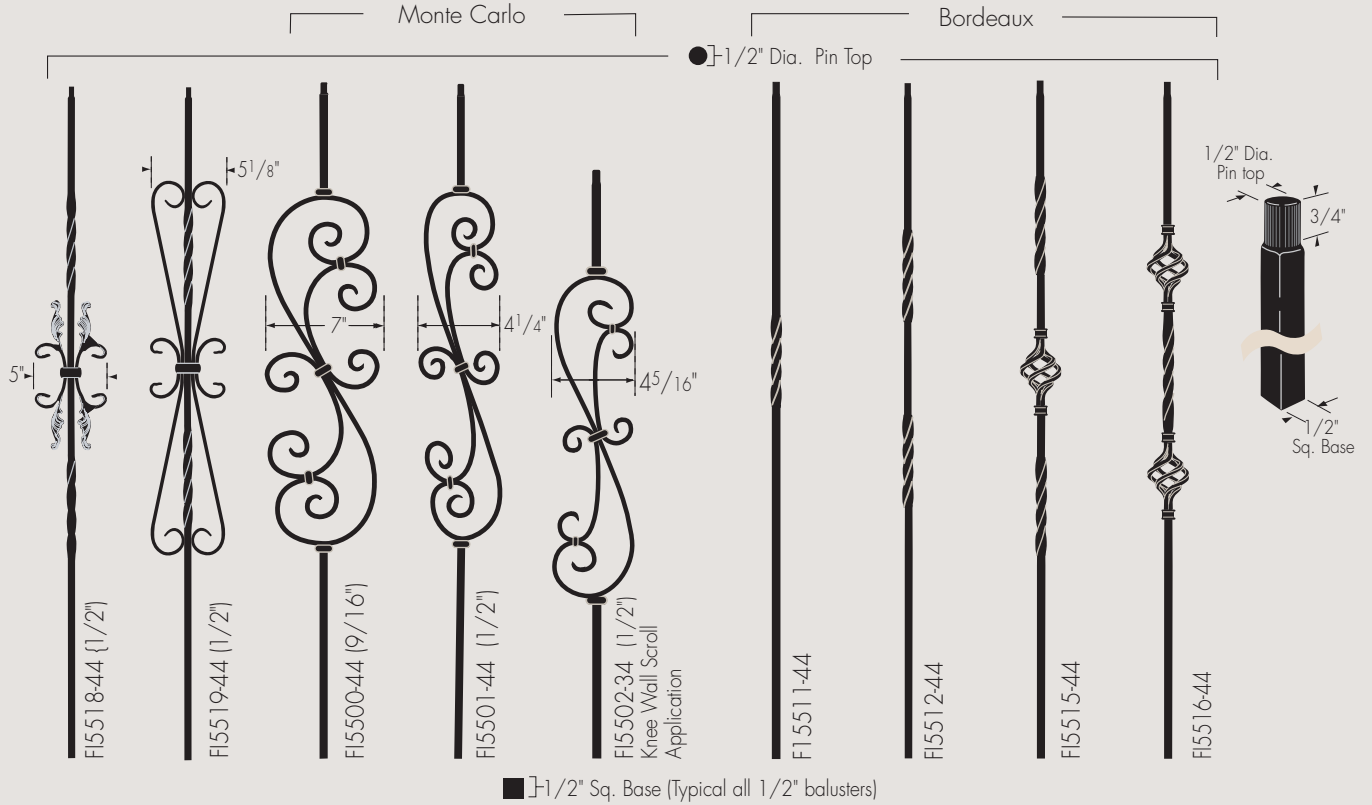

For 1/2" Balusters use:

 F13101 Shoe

 F13102 Pitch Shoe for Knee Wall Installation

 F13104 Shoe w/screws

 F13103 Adjustable Knuckle

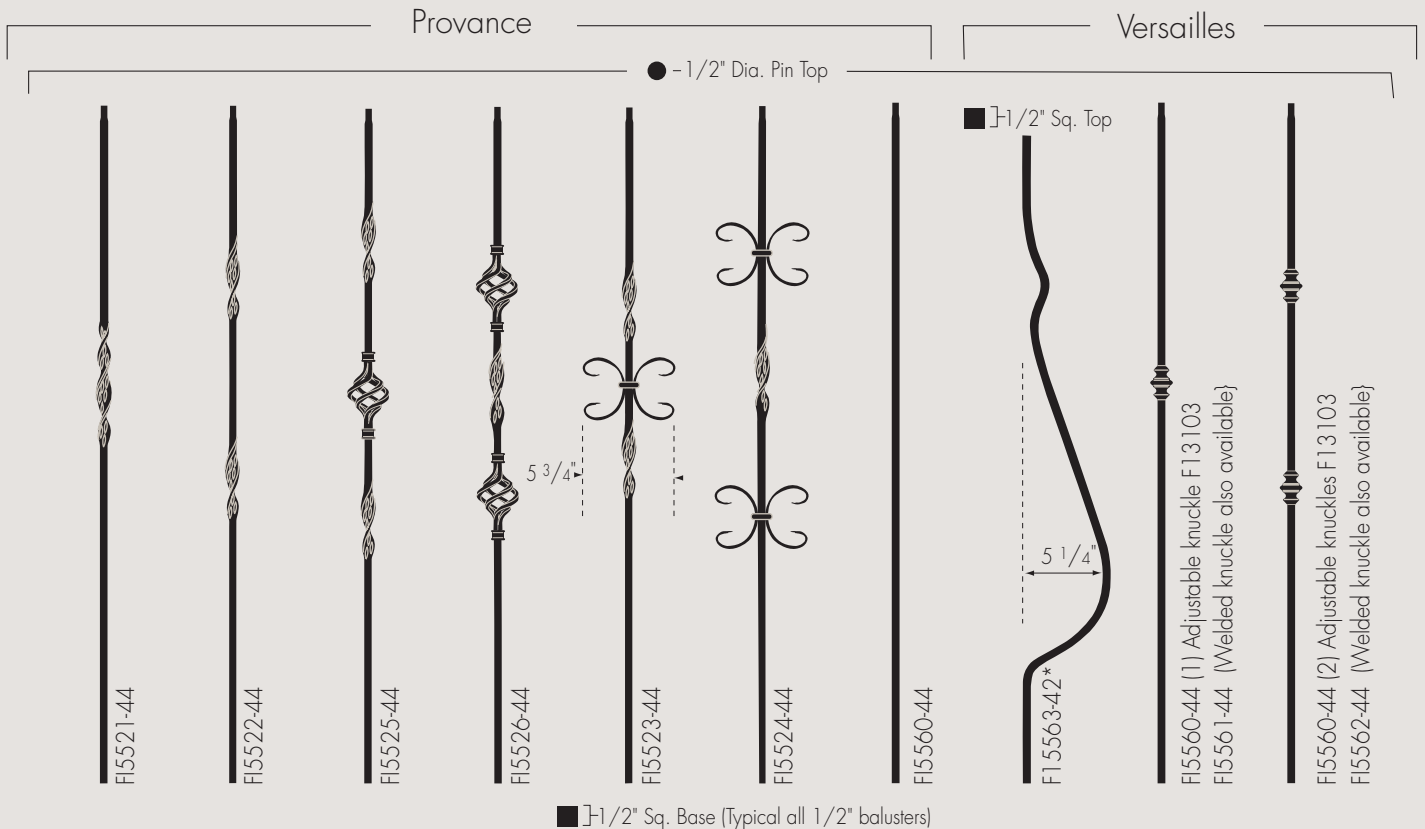

Iron Balusters

1/2 inch Balusters

Burgundy Round

Round Balusters
1/2" Dia.
1/2" Dia.

1/2" Dia. Pin Top (typ. all F15573,74 & 75 balusters)

1/2" Dia. (Typ. all F15581 & 82 balusters)

F15575-44

F15573-44

F15574-44

F15581-44 Round
Patent pending Fitts Industries, Inc.

F15581G-44 Round
Patent pending Fitts Industries, Inc.

F15582-44 Round
Patent pending Fitts Industries, Inc.

F15582G-44 Round
Patent pending Fitts Industries, Inc.

● 1/2" Round Base (Typical all F15573,74 & 75 balusters)

● 1/2" (Typical all F15581 & 82 balusters)

For 1/2" Round Balusters use:

For 9/16" Balusters use:

F13101-5 (1/2") Round Shoe 

F13102-5 (1/2") Round Shoe 

F13104-5 (1/2") Round Shoe w/screws 

F13101-2 9/16" Shoe 

F13102-2 9/16" Shoe 

F13104-2 9/16" Shoe w/screws 

9/16 inch Balusters

Tavistock

Burgundy

Phoenix

Not designed for Knee Wall Applications

1/2" Dia. Pin Top (typ. all 9/16" balusters)

1/2" Dia. Pin Top (Typ. all 9/16" balusters)

Not designed for Knee Wall Applications

Typical all 9/16 Balusters

1/2" Dia. Pin top

3/4"

9/16" Sq. Base

F15540-44

F15541-44

F15542-44

F15545-44

F15571-44

F15572-44

F15530-44

F15531-44

F15532-44

F15533-44

F15536-44

■ 9/16" Sq. Base (Typical all 9/16" balusters)

■ 9/16" Sq. Base (Typical all 9/16" balusters)



Style



& Elegance



Hemlock Stair Parts

Handrail

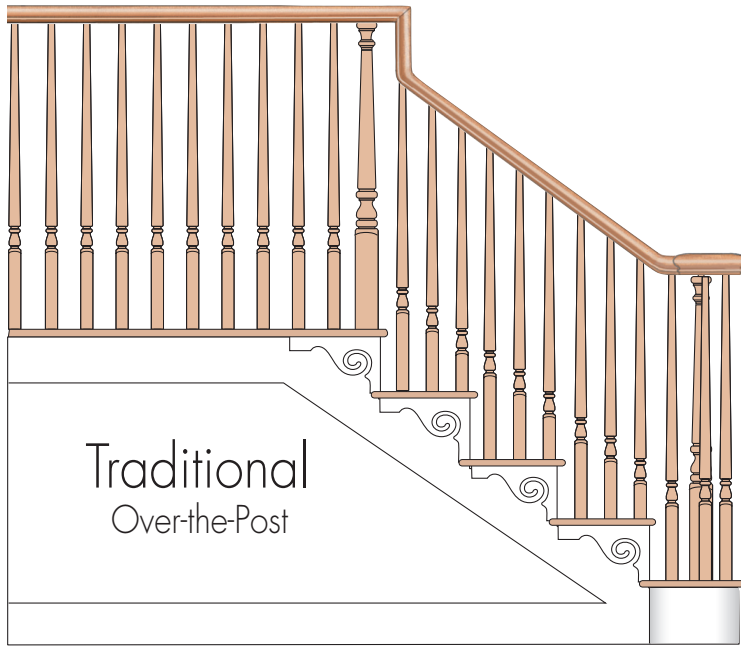

Traditional
Over-the-Post

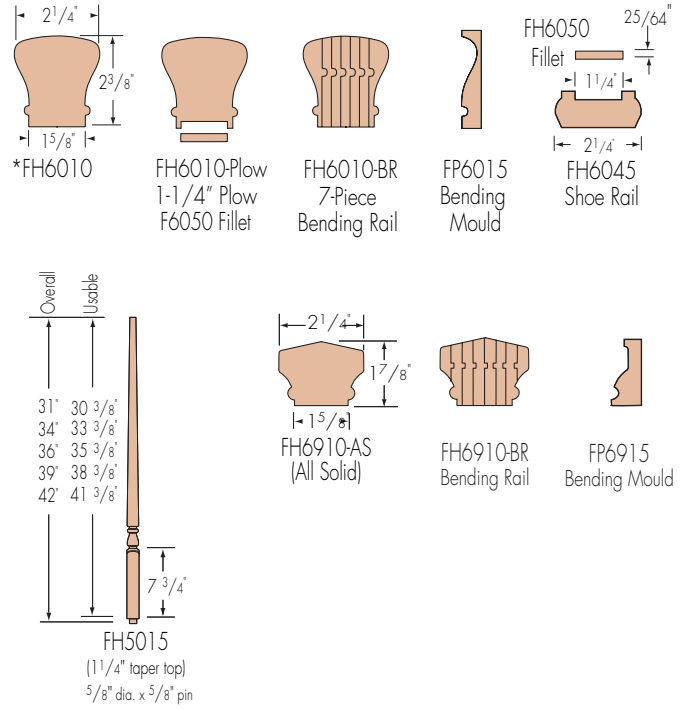

Balusters

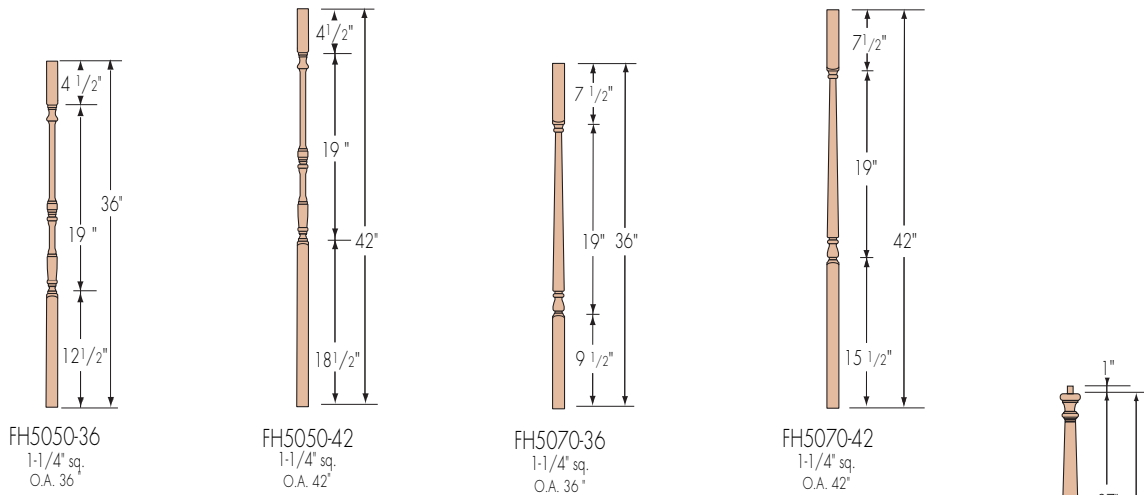

Newels

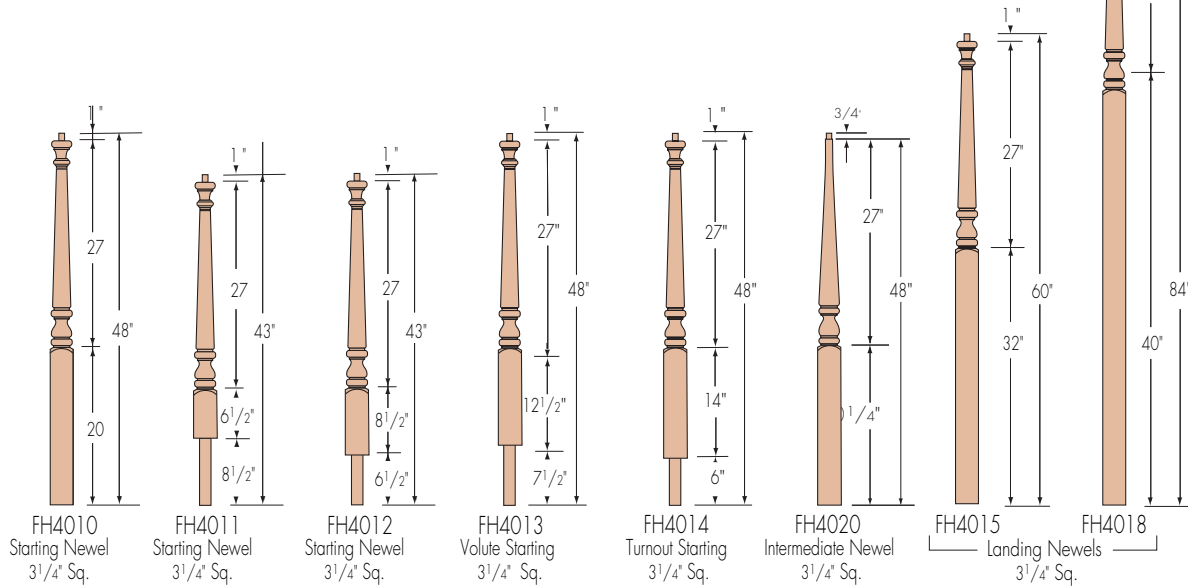

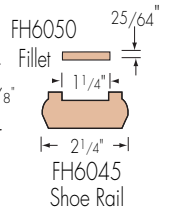
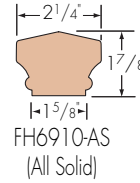
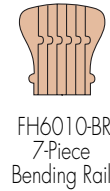
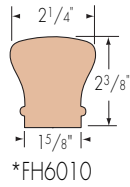
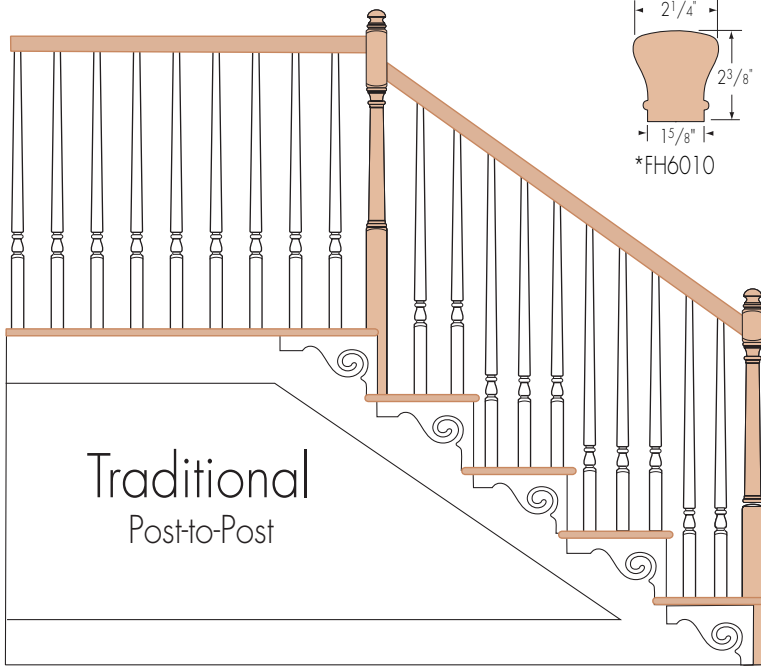

Balusters

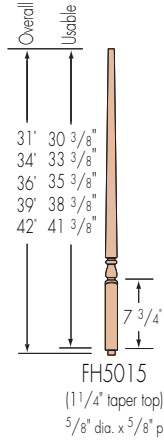

Balusters

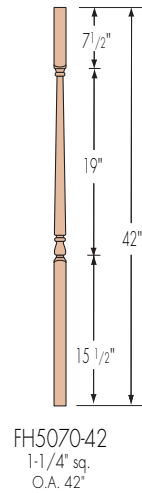
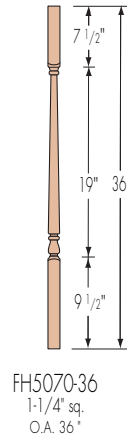
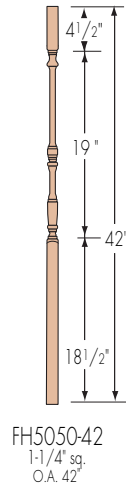
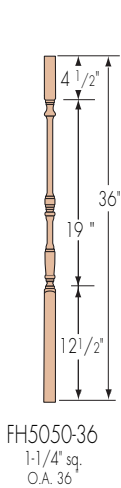

Newels

Two options available
Ball Top
Specify BT

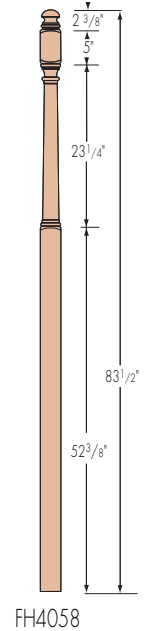
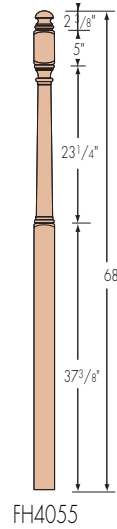
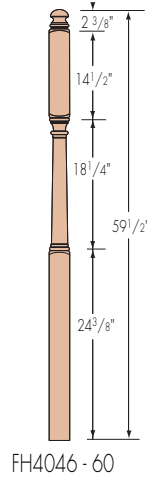
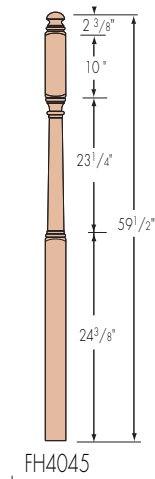
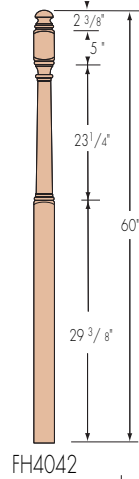
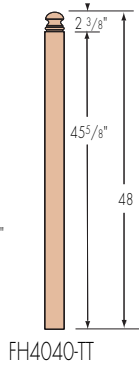
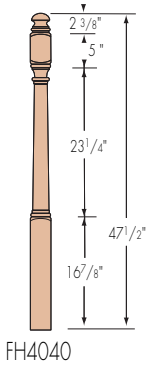

3-1/4" Starting Newels
Available in 3"

3-1/4" Landing Newels
Available in 3"



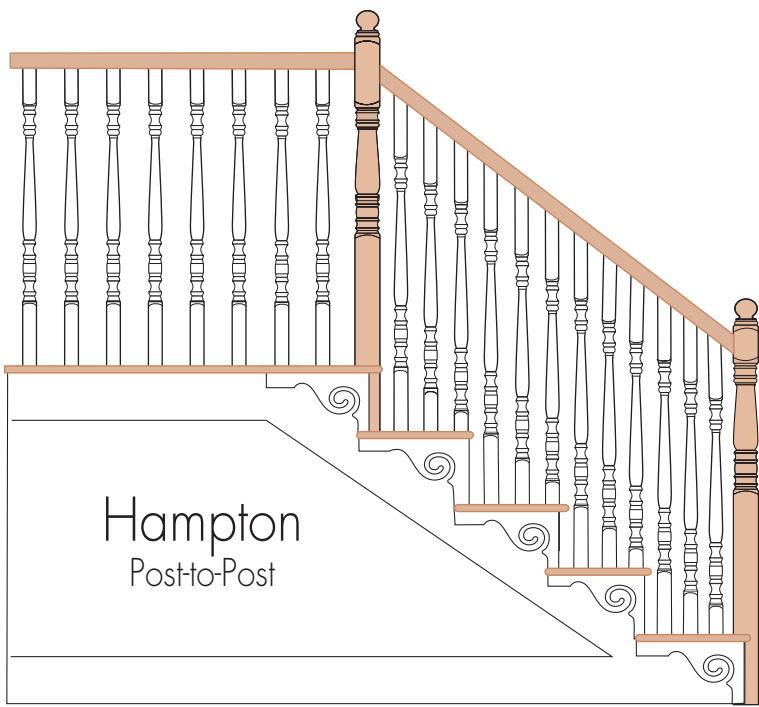

Hampton
Post-to-Post

Handrail

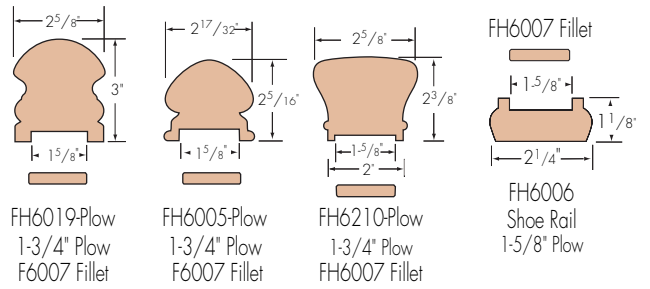

Balusters

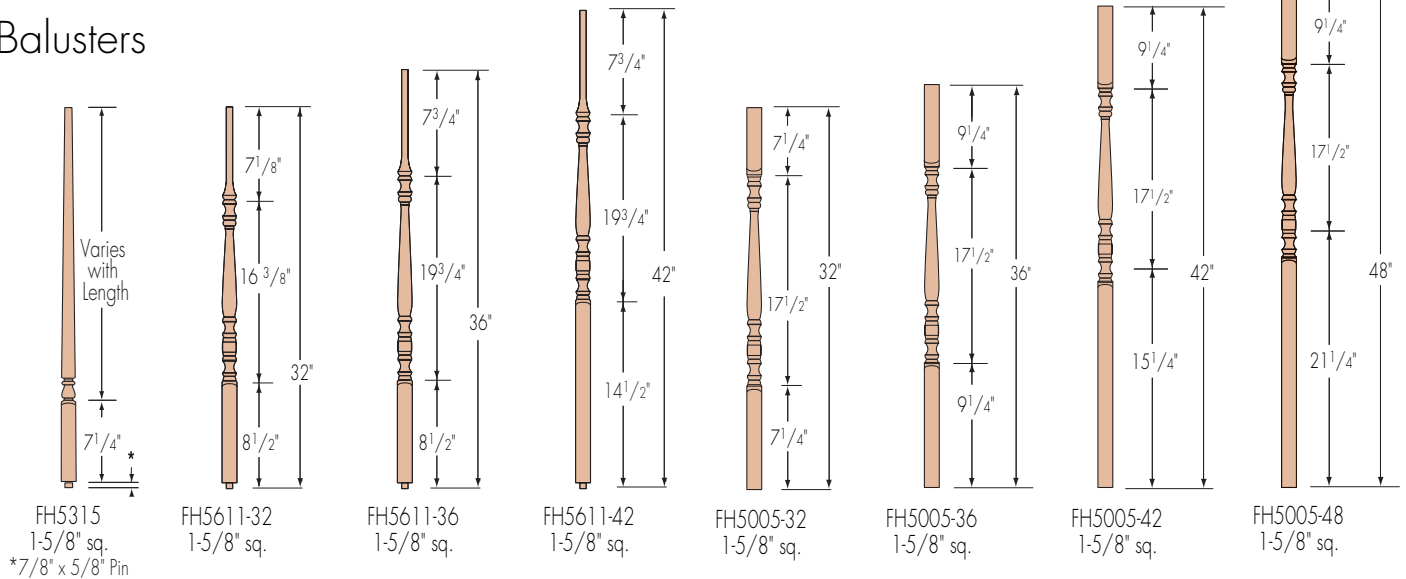

Newels

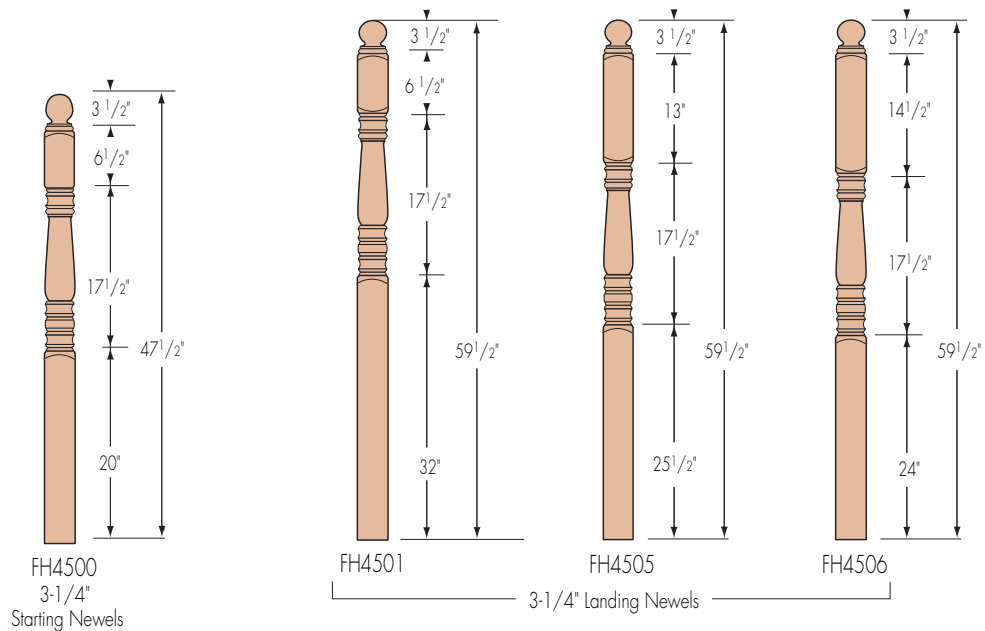

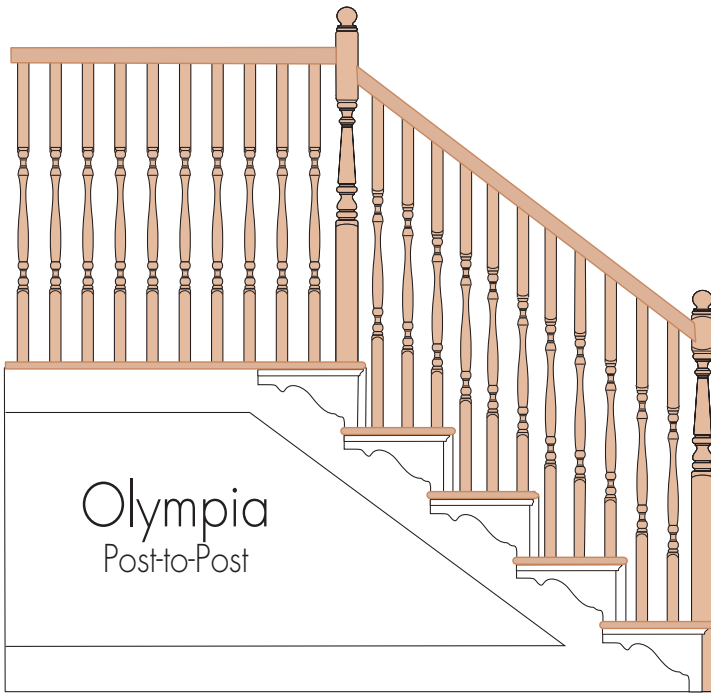

Handrail

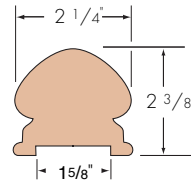

FH6005-Plow
1 5/8" Plow

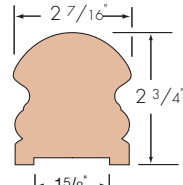

FH6019-Plow

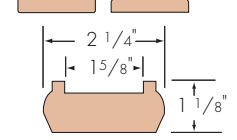
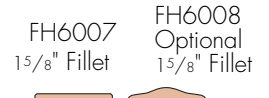

FH6006
Shoe Rail
1 5/8" Plow

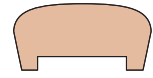

FH6244-Plow

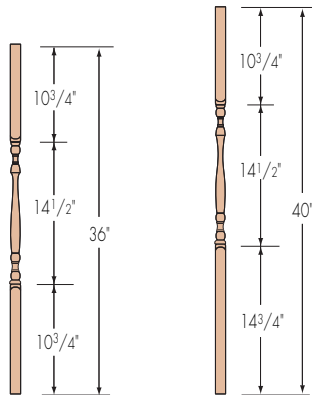

FH5801-36
1-1/4" Sq.
FH5801-40
1-1/4" Sq.
Use with non plow handrail

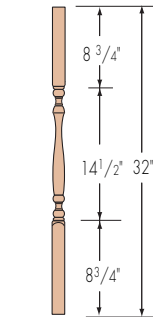

FH5802-32
1-5/8" Sq.

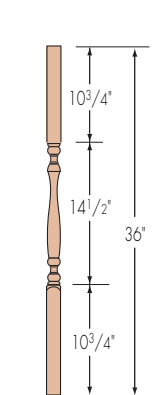

FH5802-36
1-5/8" Sq.

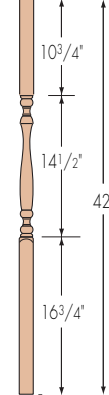

FH5802-42
1-5/8" Sq.

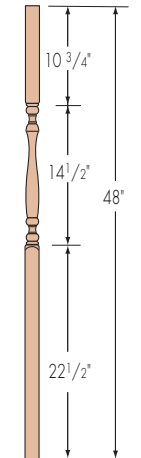

FH5802-48
1-5/8" Sq.

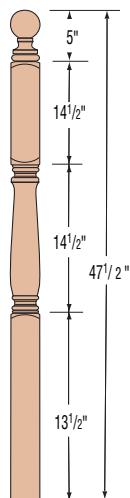

FH4840
3-1/4"
Starting Newel

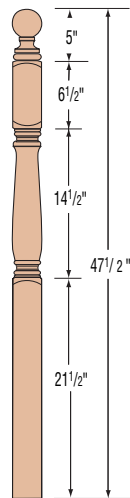

FH4842-48"
3-1/4"
Starting Newel

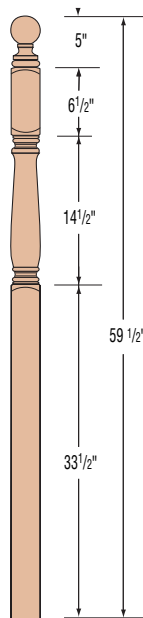

FH4842
3-1/4"
Landing Newel

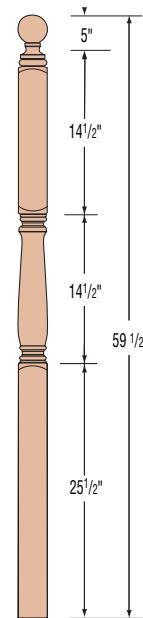

FH4846
3-1/4"
Landing Newel

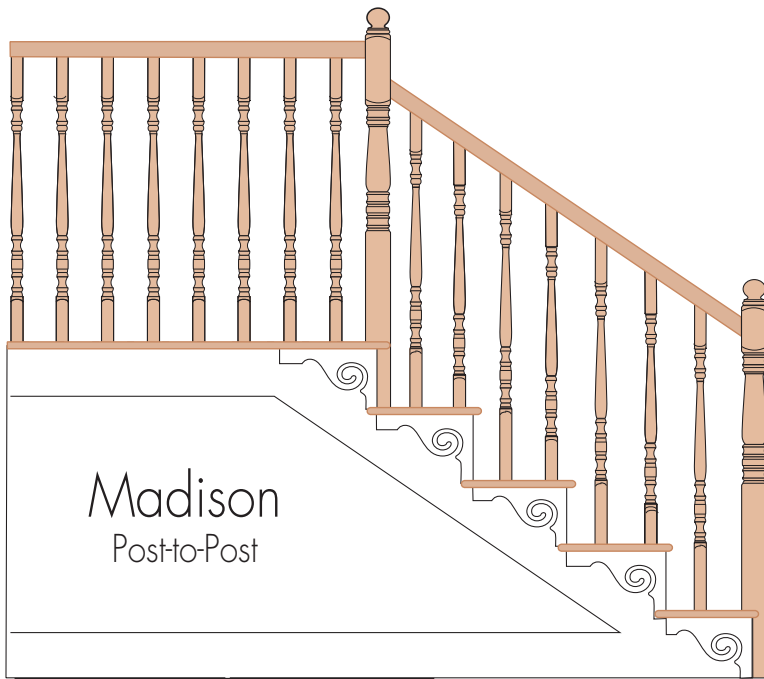

Handrail

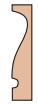
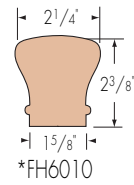

FH6010-Plow
1-1/4" Plow
FH6050 Fillet

FH6010-BR
7-Piece
Bending Rail

FP6015
Bending
Mould

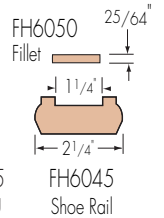
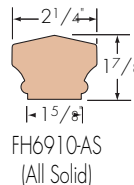

FH6910-AS
(All Solid)

FH6910-ASP
1-1/4" Plow
FH6050 Fillet

FH6910-BR
Bending
Rail

FP6915
Bending
Mould

FH6045
Shoe Rail

Balusters

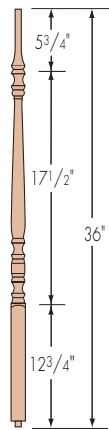

FH5610-36
1-1/4" sq.
Pin - 5/8" dia x 5/8"

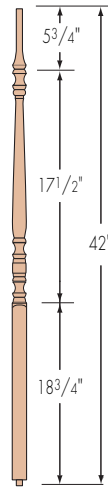

FH5610-42
1-1/4" sq.
Pin - 5/8" dia x 5/8"

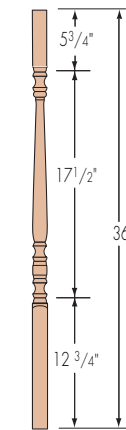

FH5105-36
1-1/4" sq.

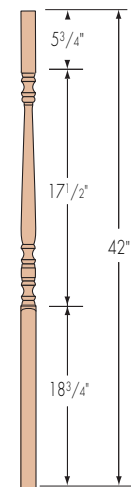

FH5105-42
1-1/4" sq.

Newels

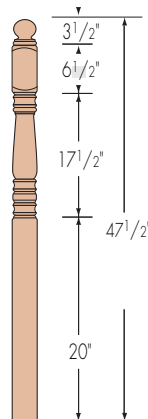

FH3500
3" Starting
Newels

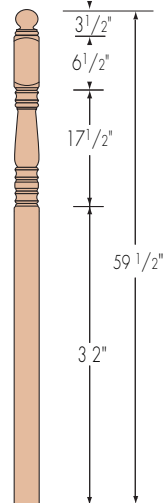

FH3501

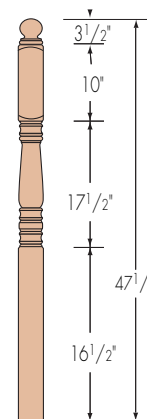

FH3503

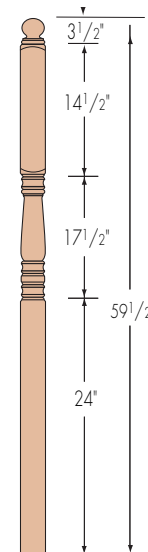

FH3505

3" Landing
Newels

Handrail

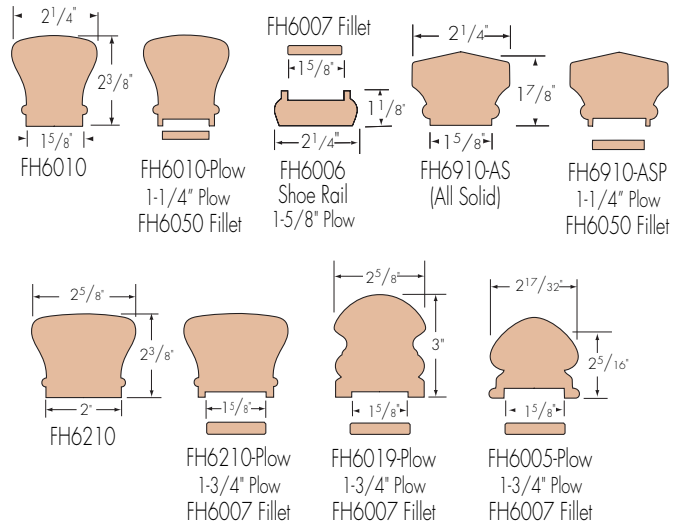

Balusters

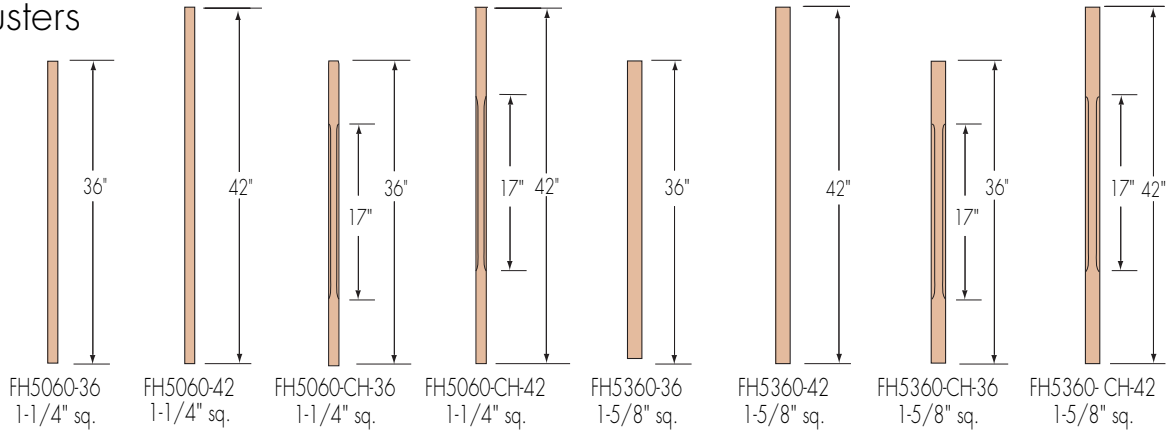

Newels

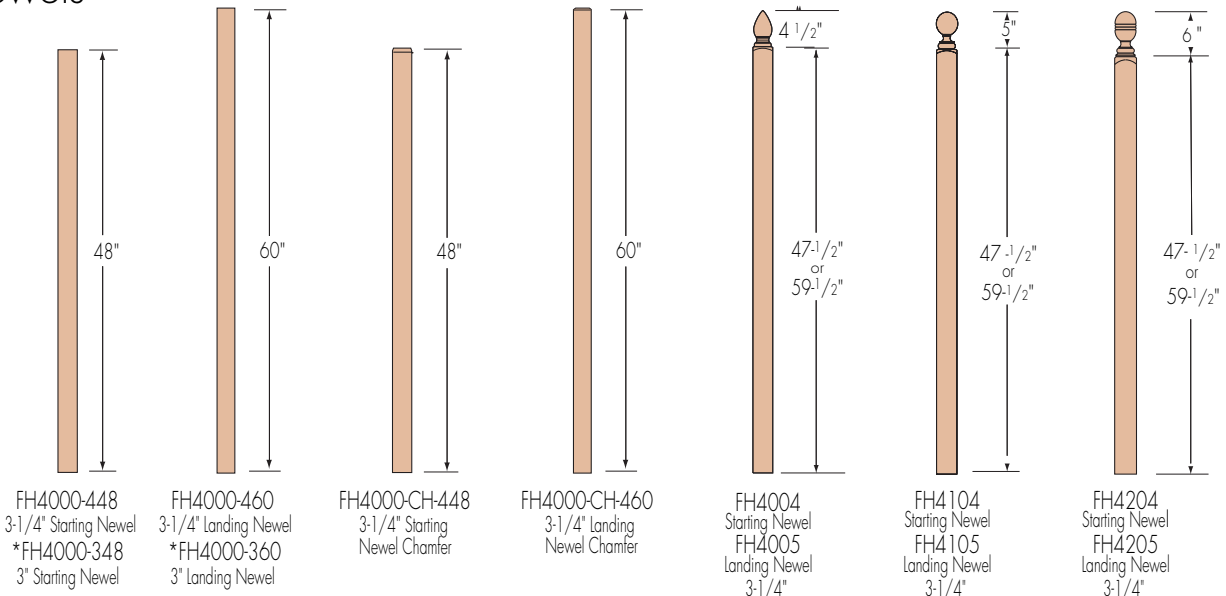

*Available Plain and Chamfered

Hemlock Fittings

Matching Handrail/Fittings

To match to Fitts Industries, Inc. handrail profiles to Fitts Industries, Inc. fittings, simply key off of the second digit of the handrail profile and the last two digits of the fitting part number

FH6010 Handrail = FH70__ Fitting

FH6910 Handrail = FH79__ Fitting

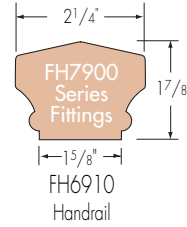
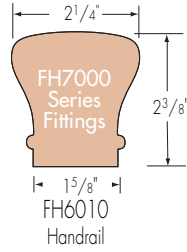

Starting Fittings

<p>FH7010 Starting Easing</p>	<p>(First Floor) UP Starting Newel with Starting Easing</p>	<p>FH7030 Left Hand Volute</p>	<p>(First Floor) UP Starting Newel with Left Hand Volute</p>	<p>FH7035 Right Hand Volute</p>	<p>(First Floor) UP Starting Newel with Right Hand Volute</p>
<p>FH7031 Left Hand Volute</p>	<p>(First Floor) UP Starting Newel with Left Hand Volute</p>	<p>FH7036 Right Hand Volute</p>	<p>(First Floor) UP Starting Newel with Right Hand Volute</p>		
<p>FH7040 Left Hand Turnout</p>	<p>(First Floor) UP Starting Newel with Left Hand Turnout</p>	<p>FH7045 Right Hand Turnout</p>	<p>(First Floor) UP Starting Newel with Right Hand Turnout</p>		
<p>FH7041 Left Hand Turnout</p>	<p>(First Floor) UP Starting Newel with Left Hand Turnout</p>	<p>FH7046 Left Hand Turnout</p>	<p>(First Floor) UP Starting Newel with Right Hand Turnout</p>		

Transitional Fittings



FH7009
Returned End

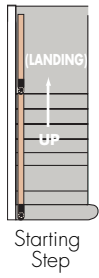

Starting Step

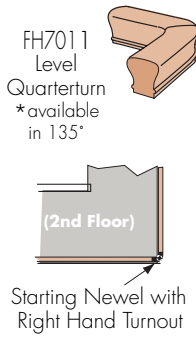

FH7011
Level
Quarterturn
*available
in 135°

Starting Newel with
Right Hand Turnout



Available
135°

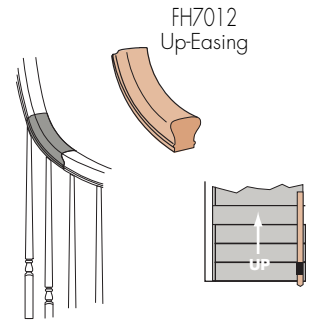

FH7012
Up-Easing



FH7013
Over-Easing

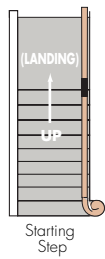

Starting Step

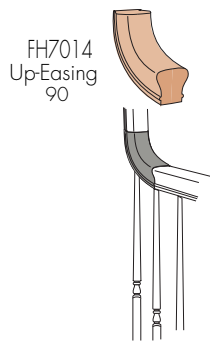

FH7014
Up-Easing
90

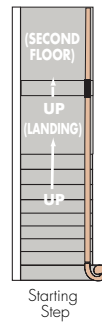

Starting Step

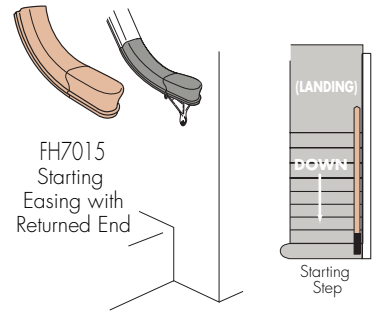

FH7015
Starting
Easing with
Returned End

Starting Step

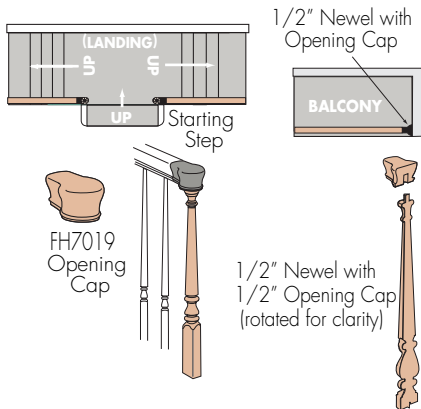

FH7019
Opening
Cap

1/2" Newel with
1/2" Opening Cap
(rotated for clarity)

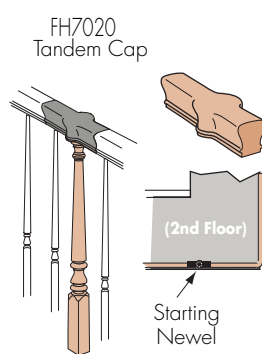
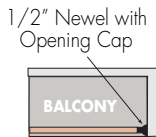

FH7020
Tandem Cap

Starting Newel

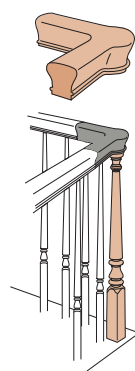

FH7021
Quarterturn Cap
*available
in 135°

135°

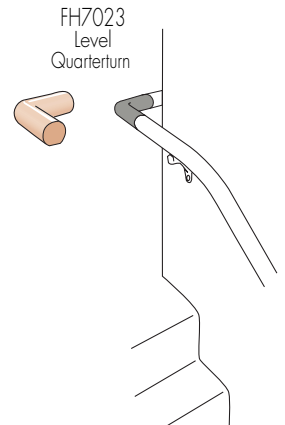
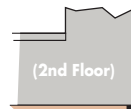

FH7023
Level
Quarterturn

Gooseneck Fittings

*Note: For increased stability, the use of a newel under all Gooseneck Fittings is strongly recommended.

*On 2-rise Goosenecks bottom Up-Easing is unattached for adjustment in the field.

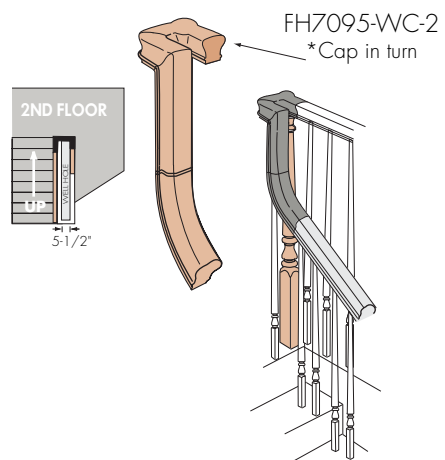
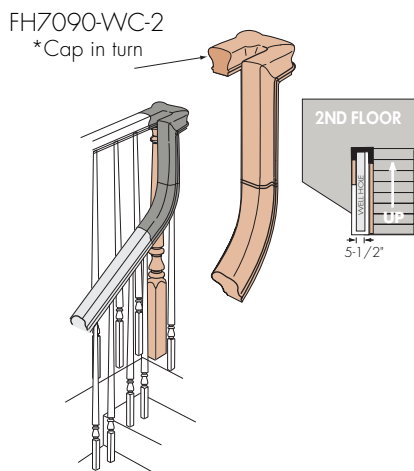
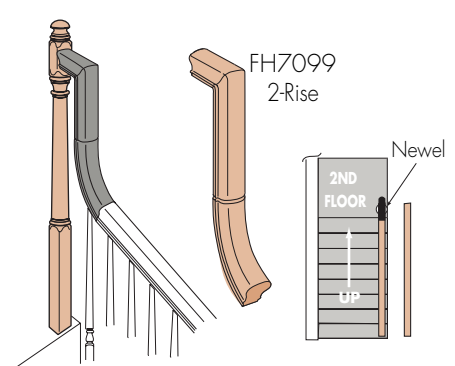
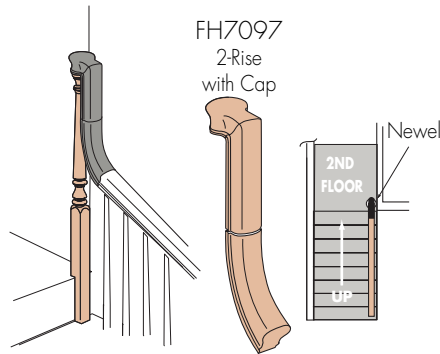
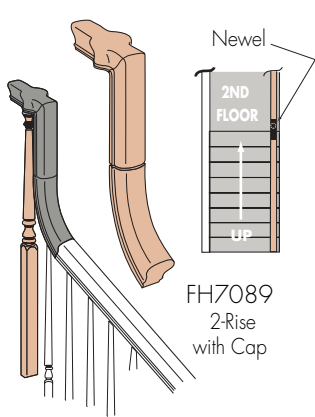
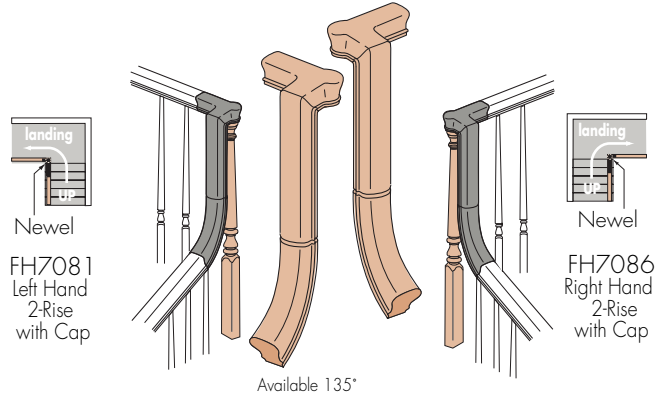
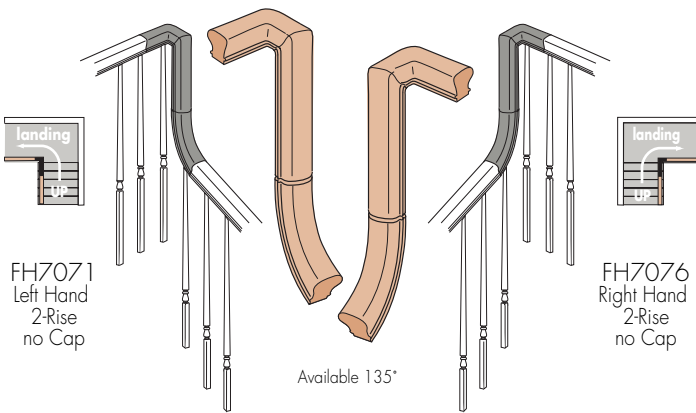
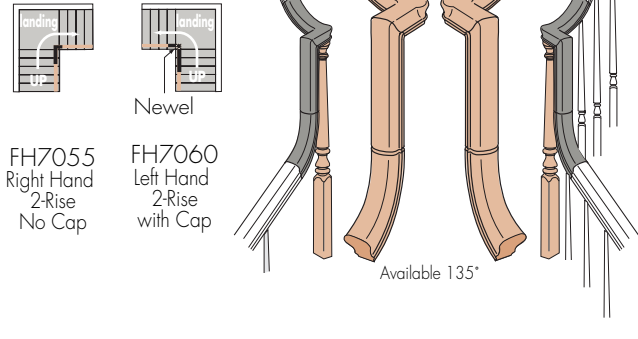
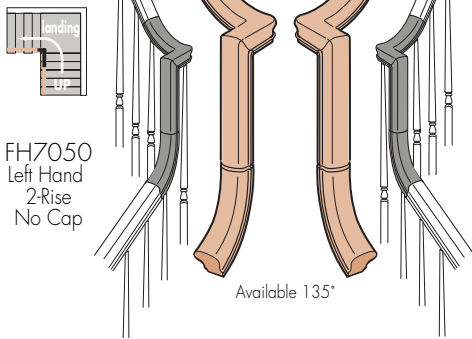

Treads, Risers, Starting Steps & Tread Caps

All Fitts Industries, Inc. Starting Steps Include:

- Radius Shoe and Cove Mould
- Straight Shoe & Cove Mould
- The Option to Specify Paint Grade or Stain Grade Risers
- Reversible Single Bullnose

Specifications:

- Starting Step Tread – 1" x 11-1/32"
- Riser – 3/4" x 7" (Overall Rise 8" w/Tread)
- Widths – are specified to outside of finished stringers, taking into consideration skirt board, sheetrock and tread brackets if applicable.

False End Starting Step

FH8011 — Use with FH6010, Handrail with Turnout or Volute when carpeting the stair.

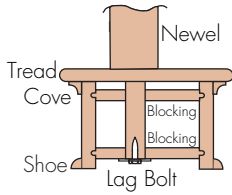
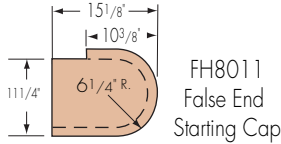

FH8010 and FH8015-48
Use with FH6010, with Turnout and Volutes.

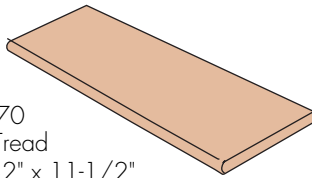
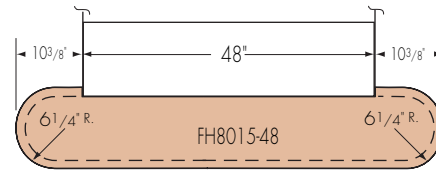
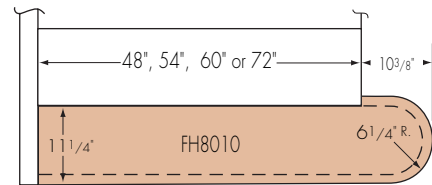

FH8070
Plain Tread
1-1/32" x 11-1/2"
Standard Lengths
36", 42", 48", 60", 72"

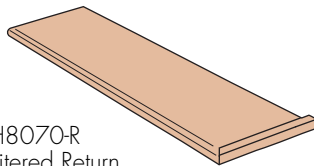

FH8070-R
Mitered Return
1-1/32" x 11-1/2"
Standard Lengths
36", 42", 48", 60", 72"

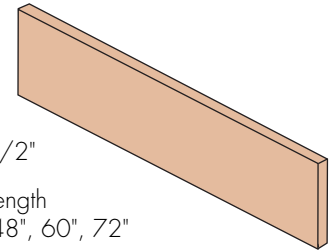

FH8075
Riser
3/4" x 7-1/2"
3/4" x 8"
Standard Length
36", 42", 48", 60", 72"

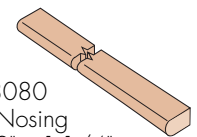
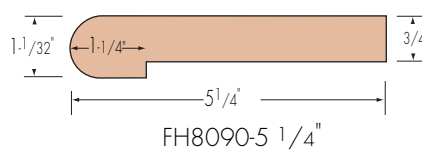
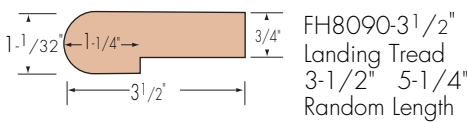

FH8080
Linear Nosing
1-1/32" x 1-1/4"
Random Length
Nosing

FH8422
Shoe Mould
1/2" x 3/4"
Random Length
Base Trim

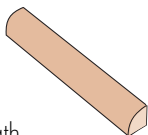

FH8095
Cove Mould
3/4" x 3/4"
Random Length

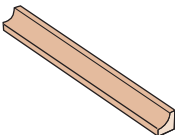

Winder Treads & Platform

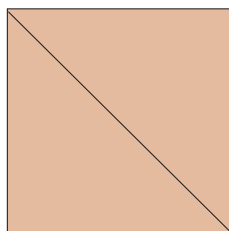

2-Piece Winder Tread

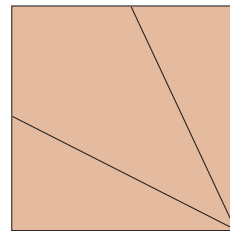

3-Piece Winder Tread

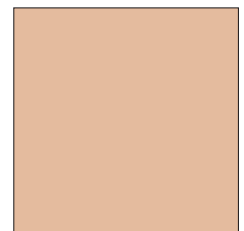

Platform

Knotty Pine

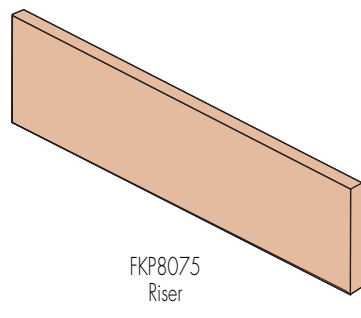
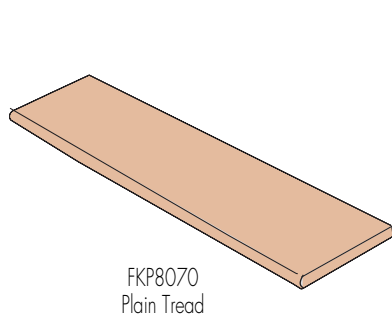
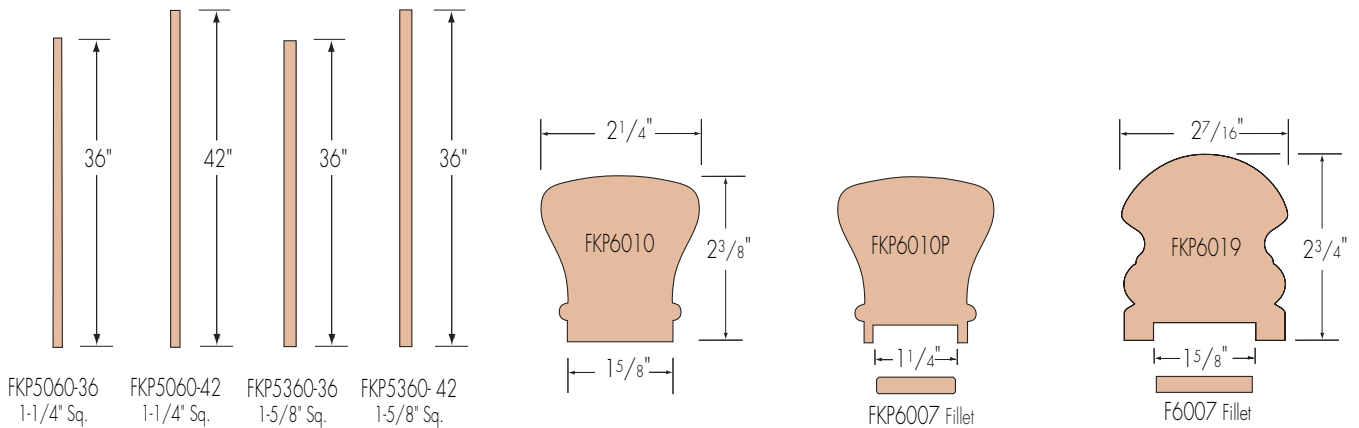
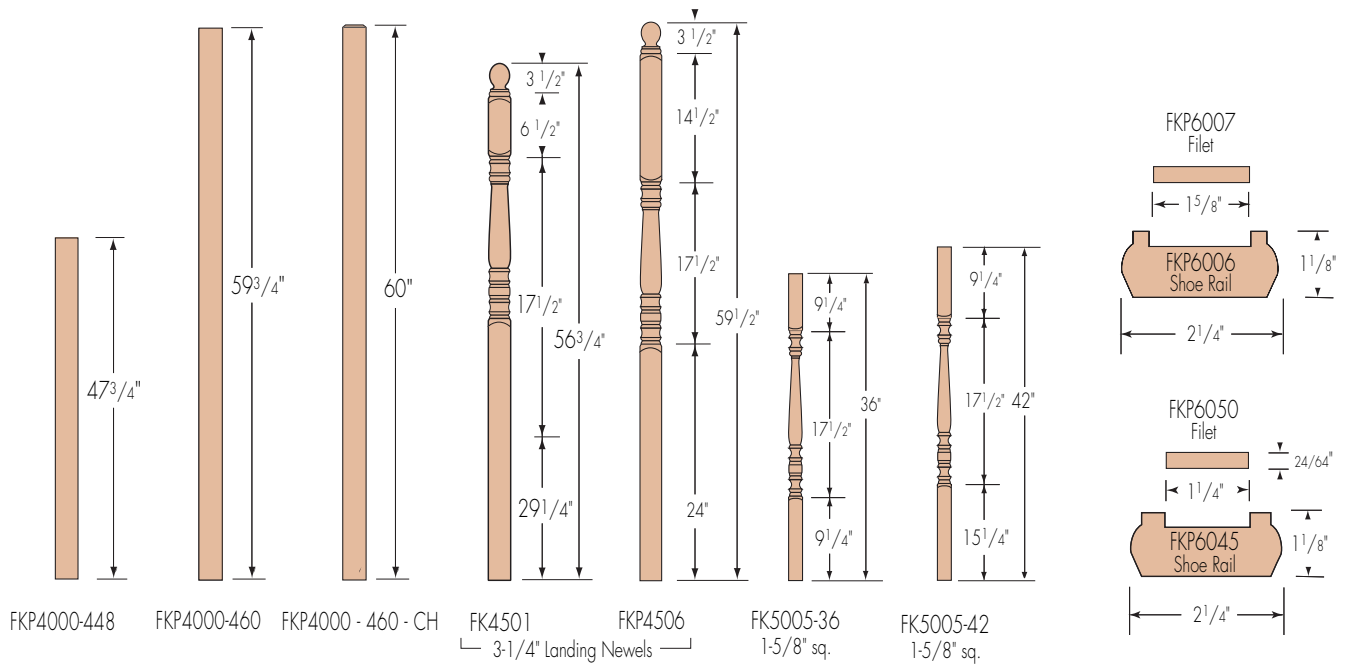



Hardwood Stair Parts

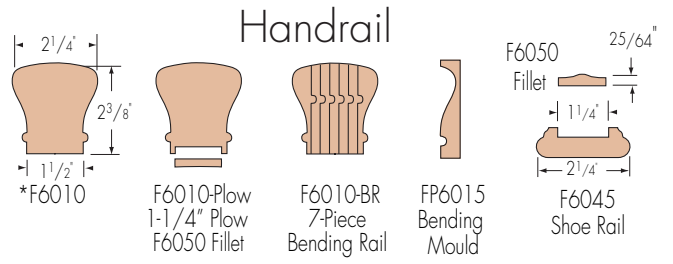
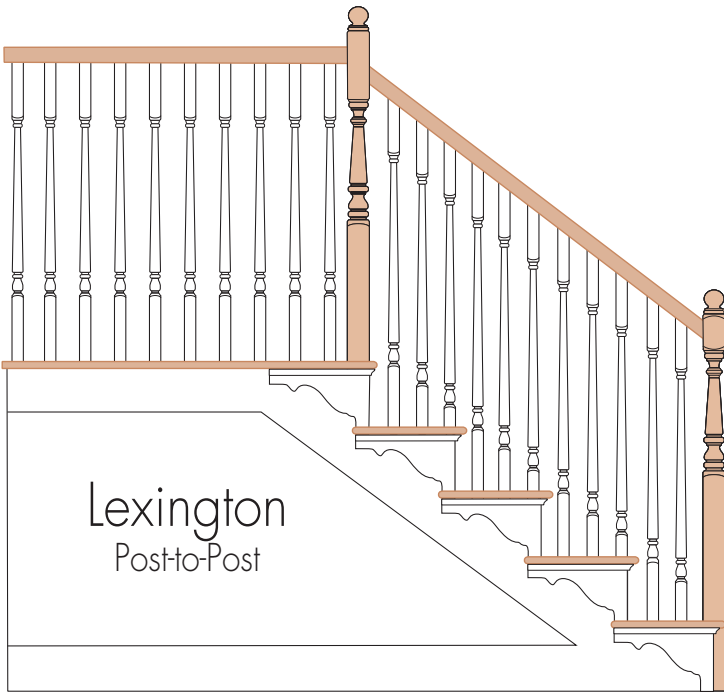

Balusters

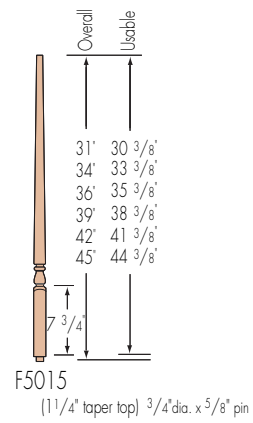

Balusters

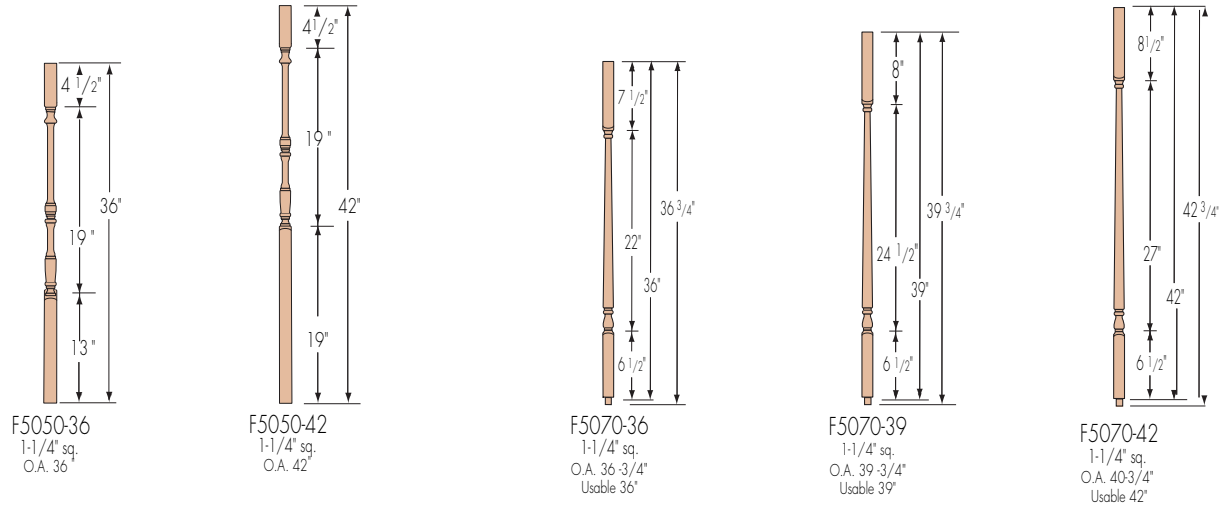

Balusters

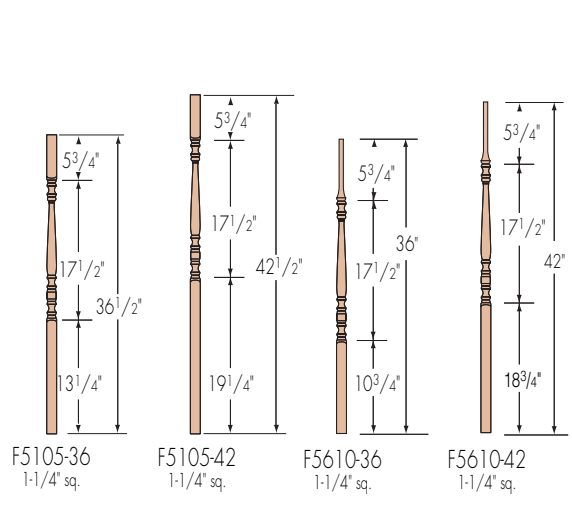

Newels

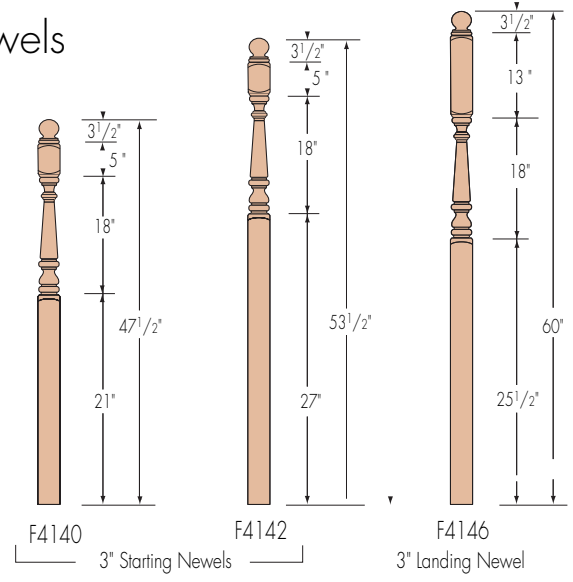

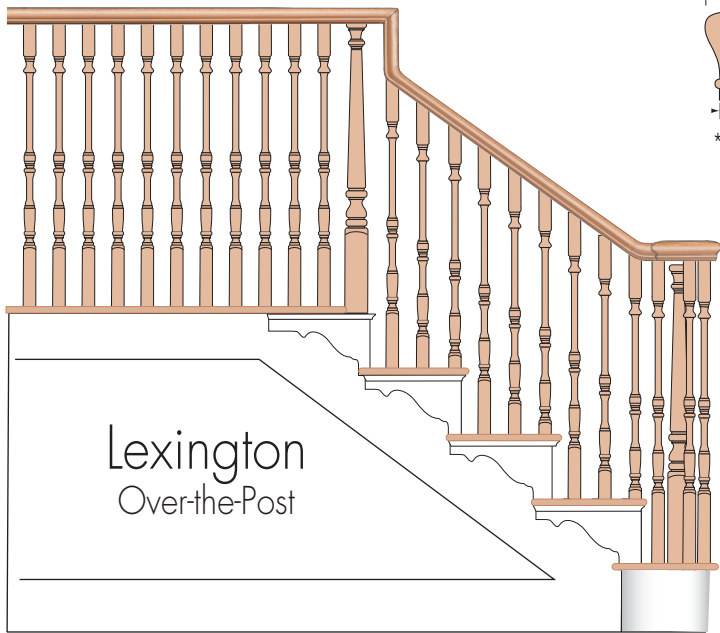

Lexington
Over-the-Post

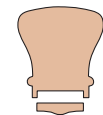
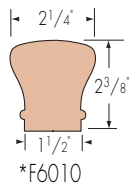

F6010-Plow
1-1/4" Plow
F6050 Fillet

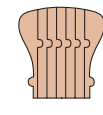

F6010-BR
7-Piece
Bending Rail



FP6015
Bending
Mould

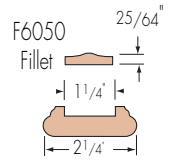

Handrail

Balusters

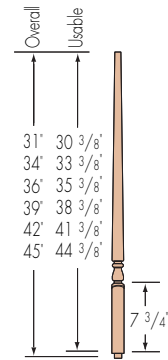

Balusters

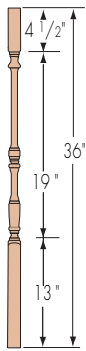

F5050-36
1-1/4" sq.
O.A. 36"

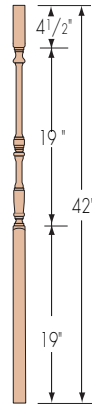

F5050-42
1-1/4" sq.
O.A. 42"

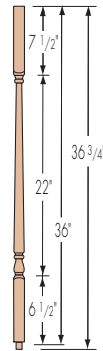

F5070-36
1-1/4" sq.
O.A. 36 3/4"
Usable 36"

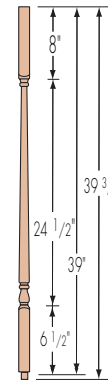

F5070-39
1-1/4" sq.
O.A. 39 3/4"
Usable 39"

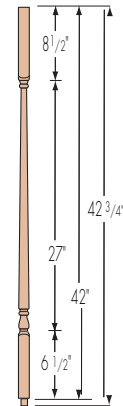

F5070-42
1-1/4" sq.
O.A. 40 3/4"
Usable 42"

Newels

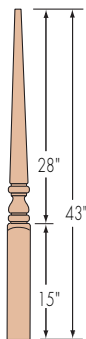

F4020
L Starting
Newel 3" Sq.

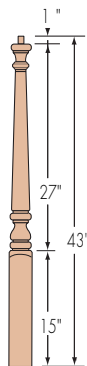

F4010
L Starting
Newel 3" Sq.

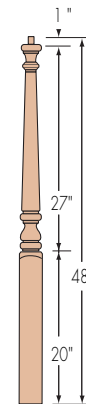

F4010-48
L Starting
Newel 3" Sq.

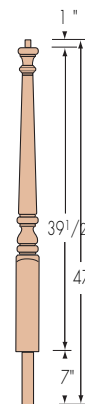

F4013
L Volute
Starting 3" Sq.

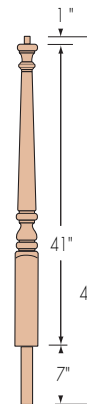

F4014
L Turnout
Starting 3" Sq.

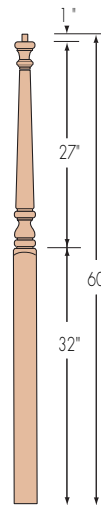

F4015

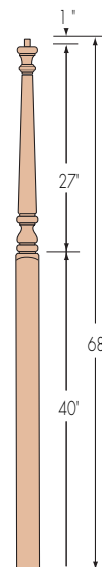

F4017

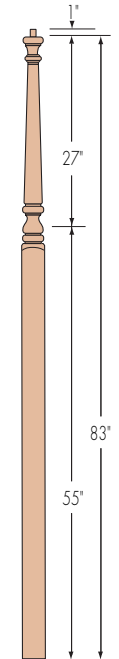

F4018

Landing Newels
3" Sq.

Handrail

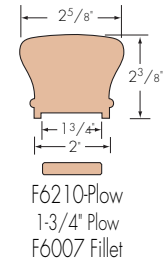
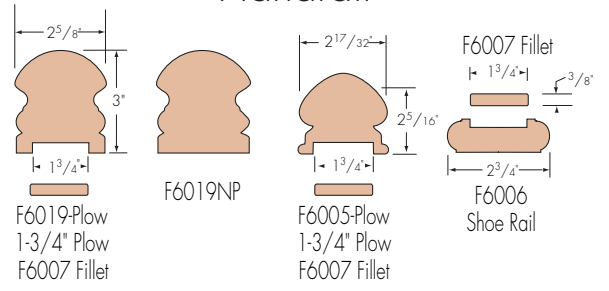
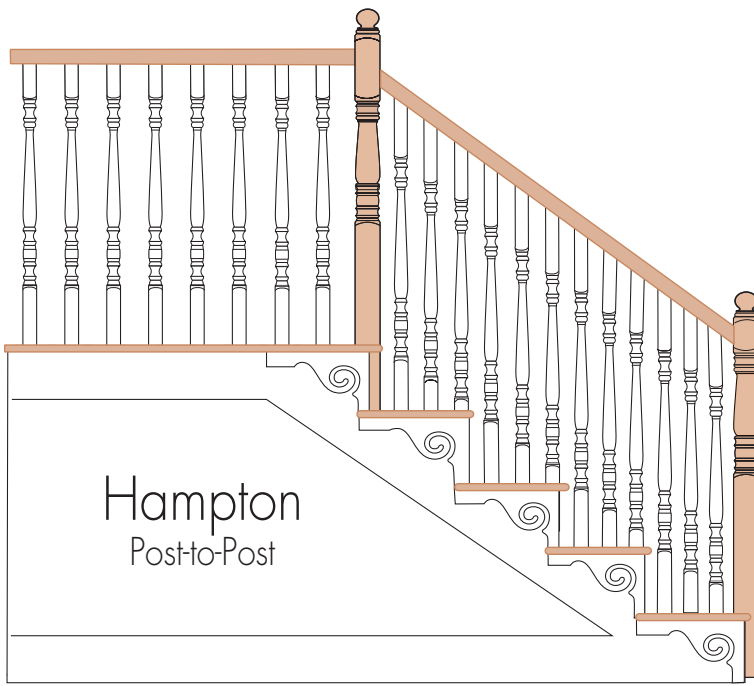

Balusters

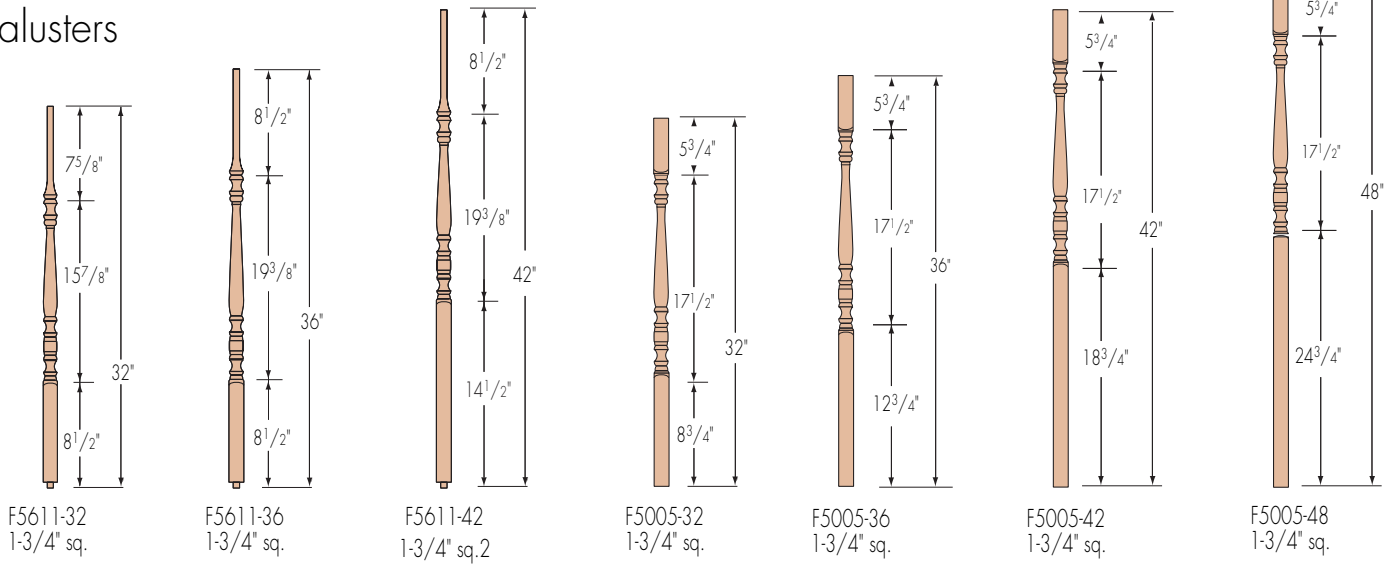

Newels

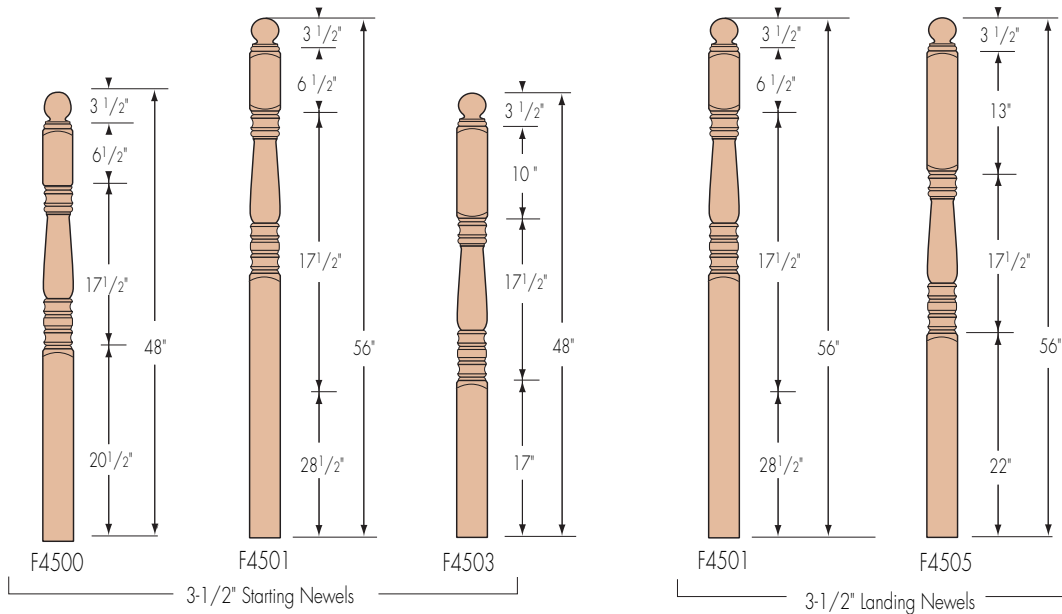

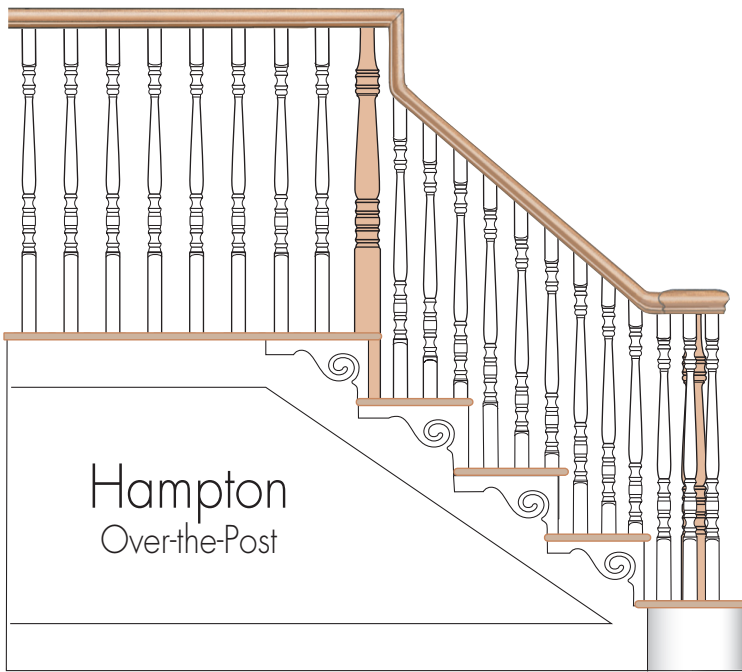

Handrail

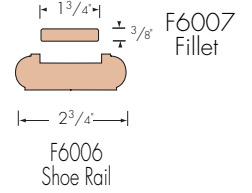
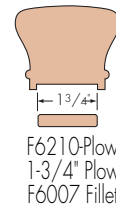
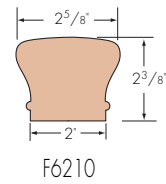

Balusters

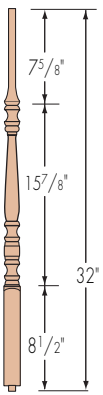

F5611-32
1-3/4" sq.

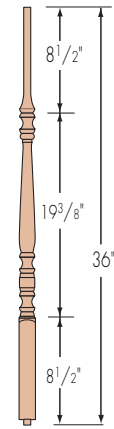

F5611-36
1-3/4" sq.

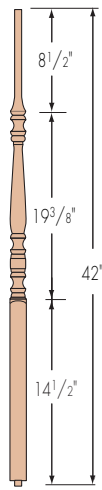

F5611-42
1-3/4" sq.

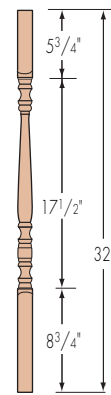

F5005-32
1-3/4" sq.

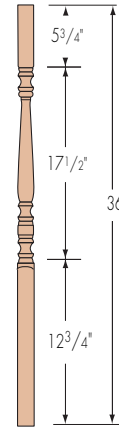

F5005-36
1-3/4" sq.

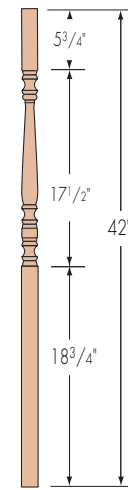

F5005-42
1-3/4" sq.

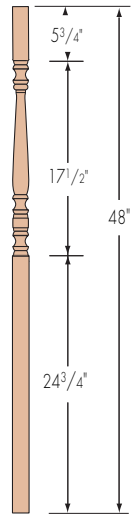

F5005-48
1-3/4" sq.

Newels

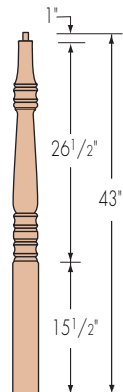

F4210
Starting Newel 3 1/2"

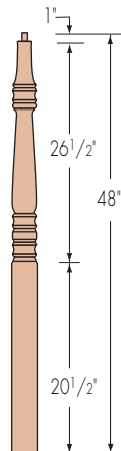

F4210-48
Starting Newel 3 1/2"

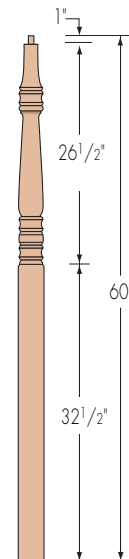

F4215
Landing Newel 3 1/2"

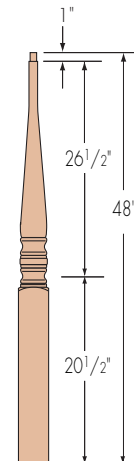

F4220
Starting Newel 3 1/2"

Handrail

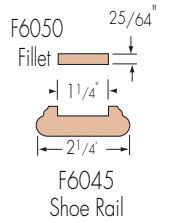
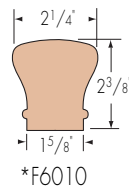

Balusters

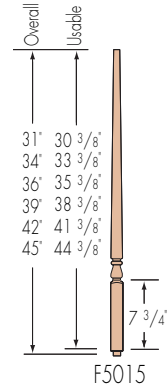

(1 1/4" taper top) 3/4" dia. x 5/8" pin

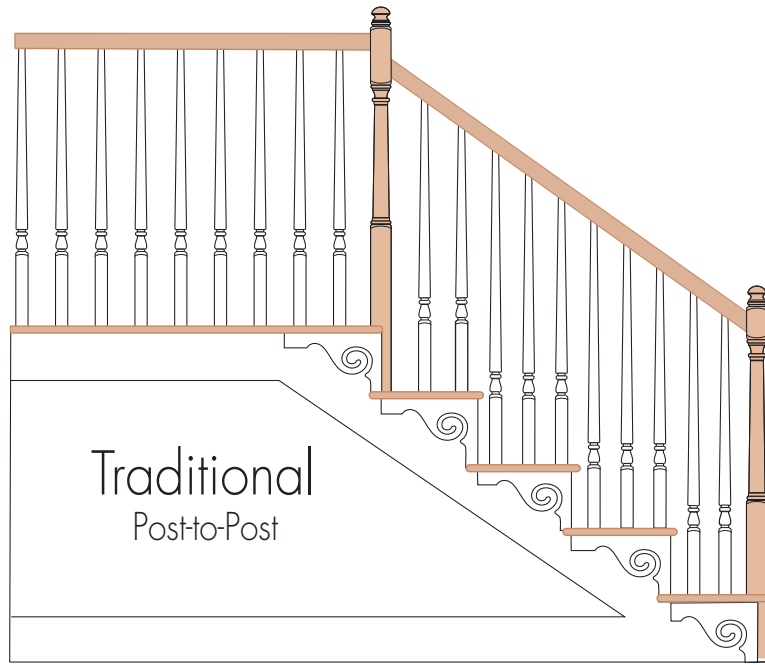

Balusters

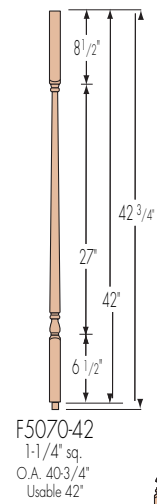
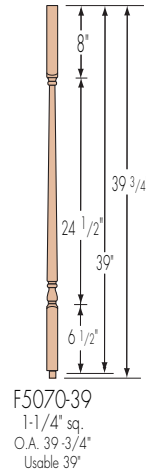
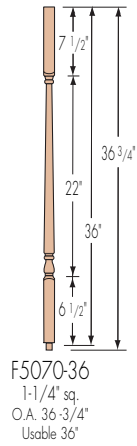
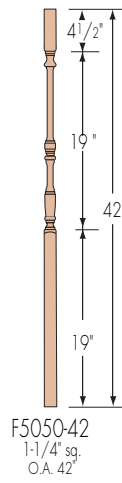
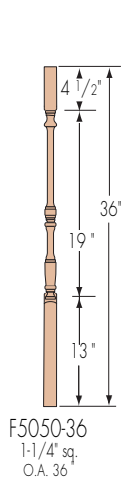

Newels

Specify
BT

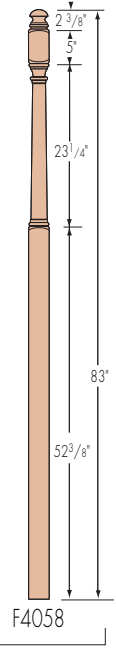
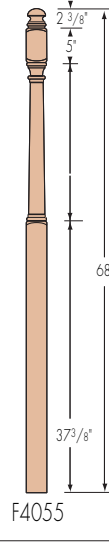
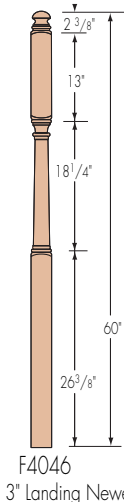
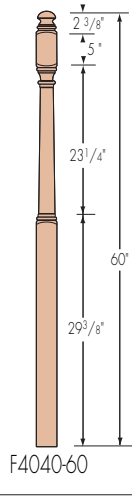
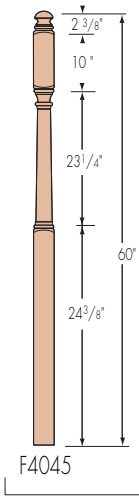
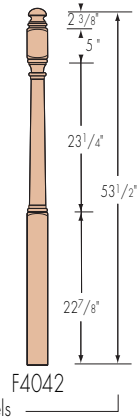
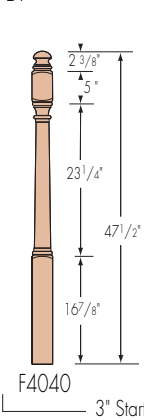

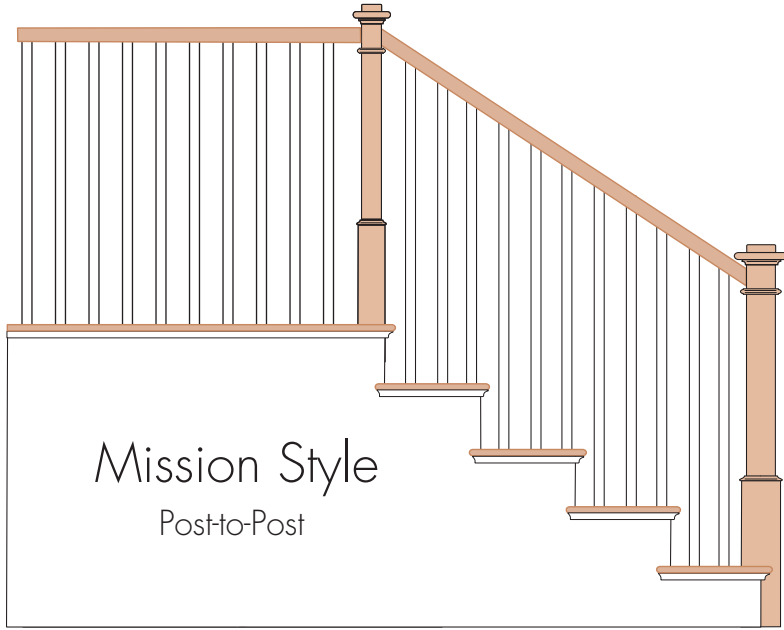

Handrail

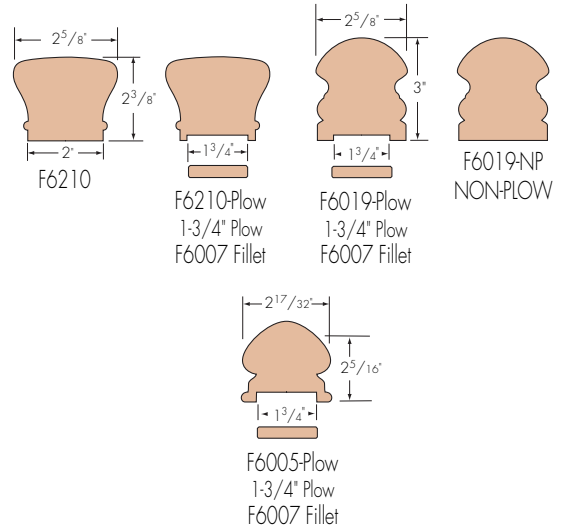

Balusters

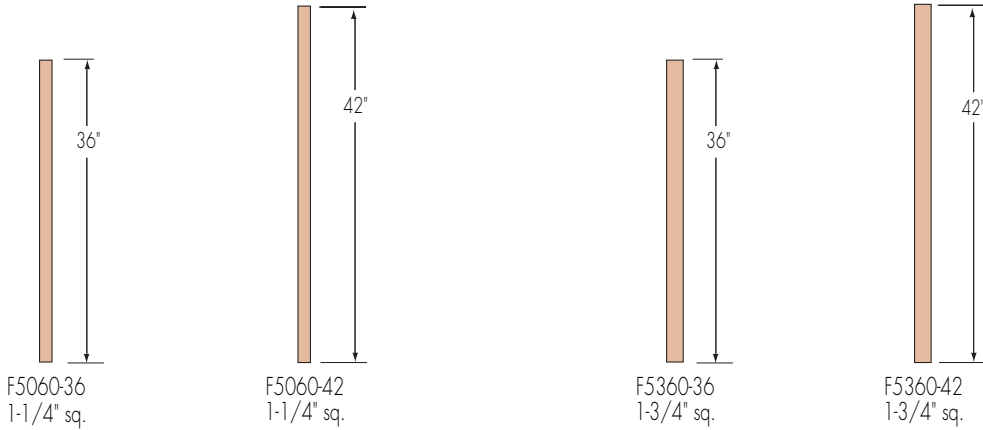

Newels

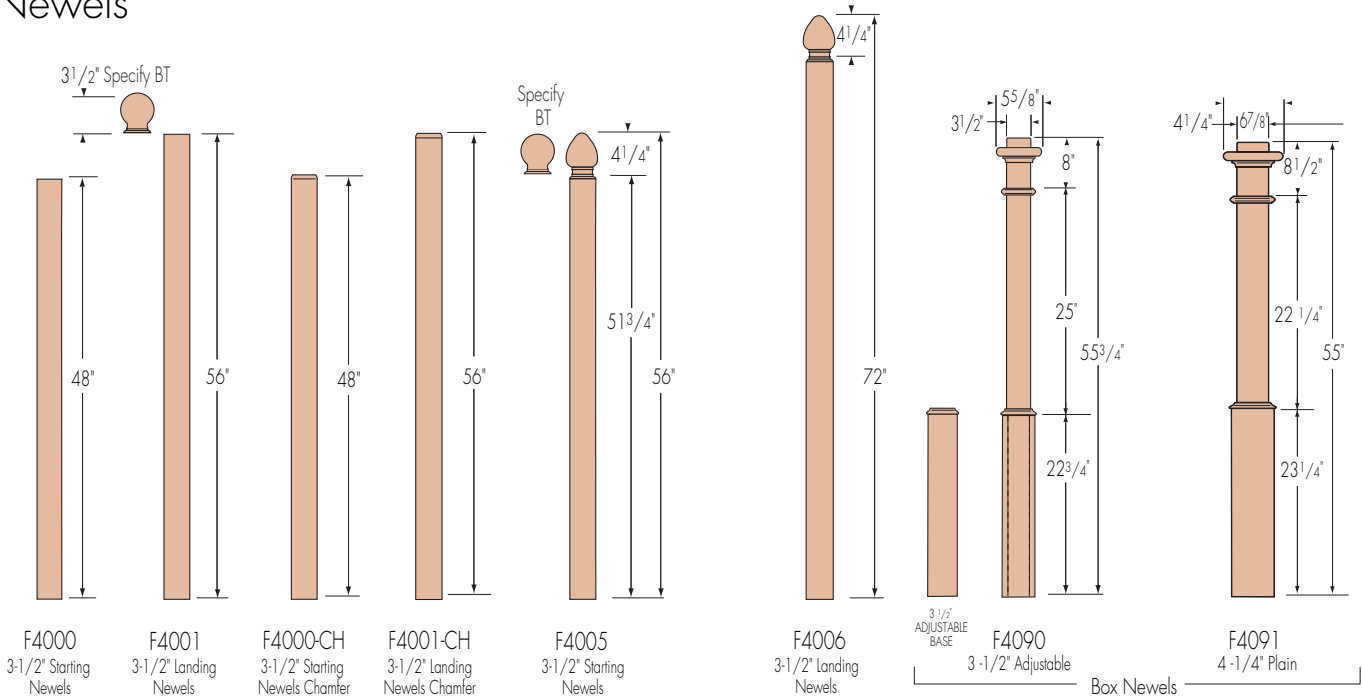

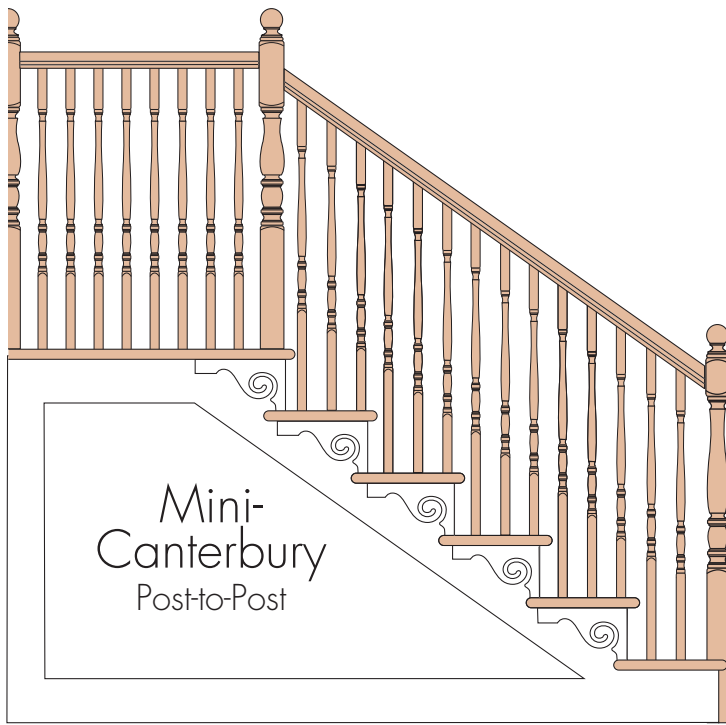

Handrail

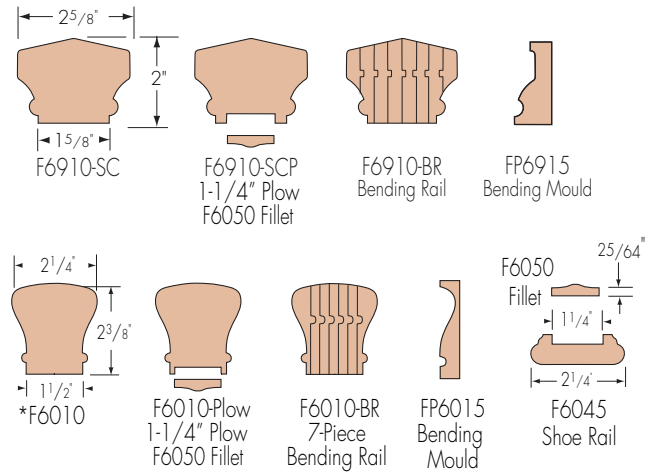

Balusters

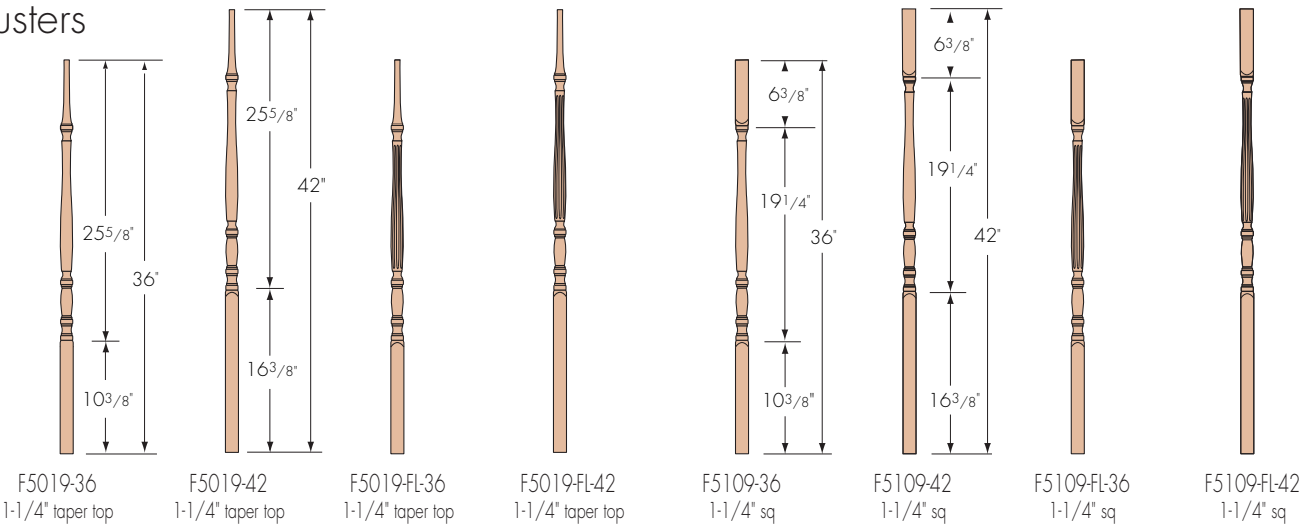

Newels

Specify "A" for Acorn Top

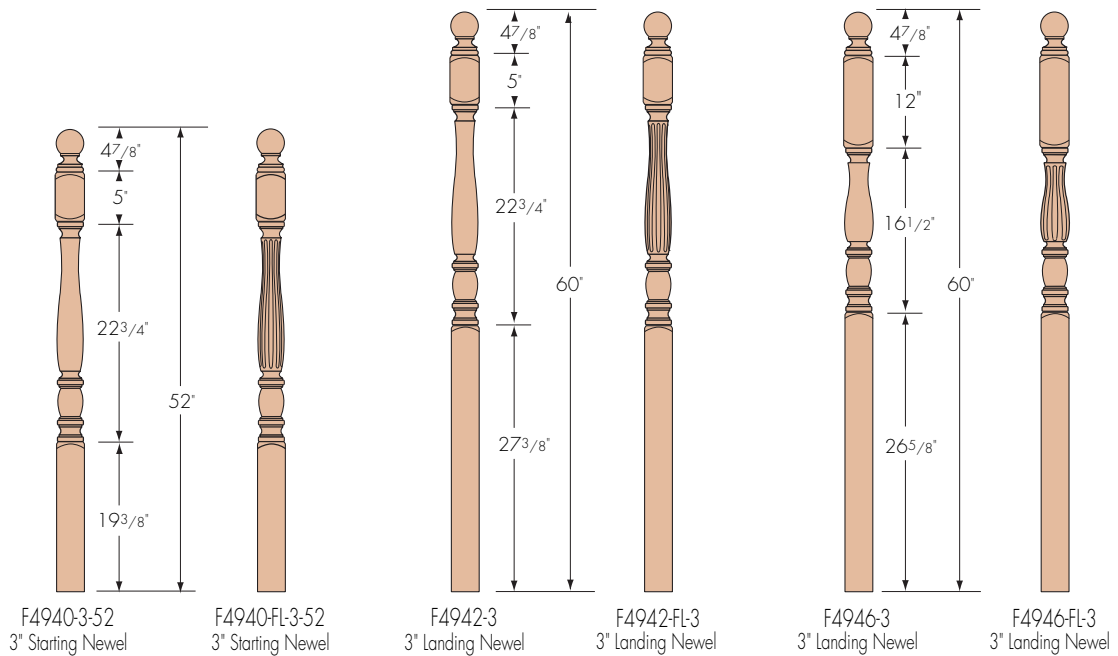

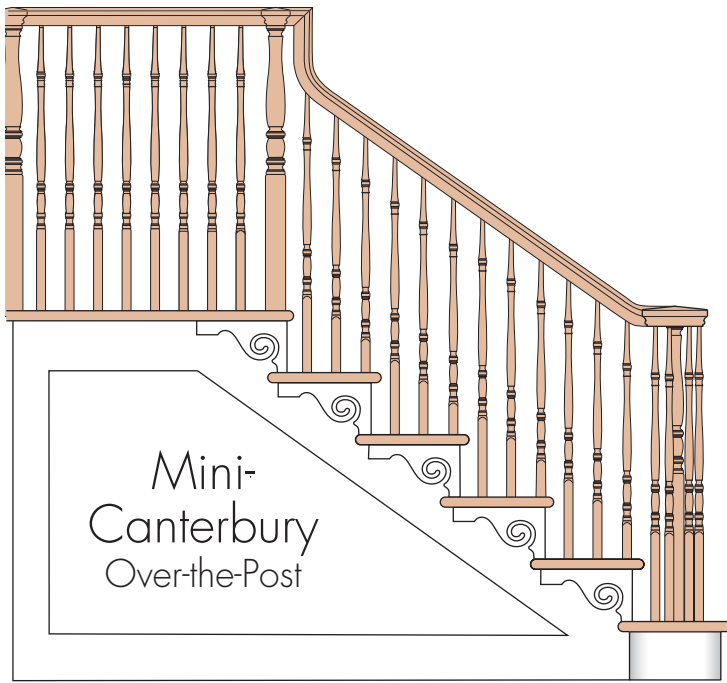

Handrail

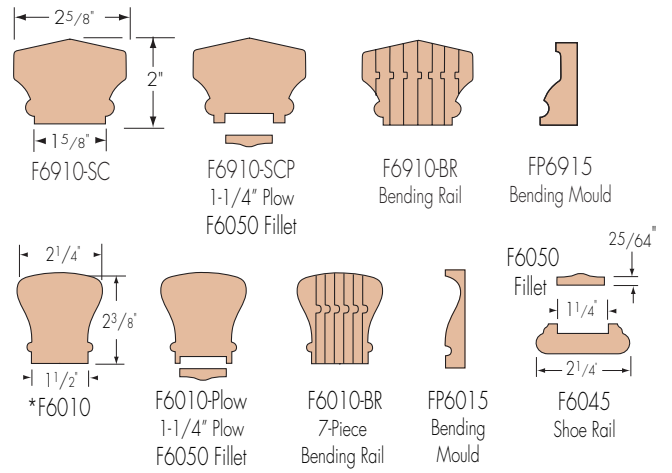

Balusters

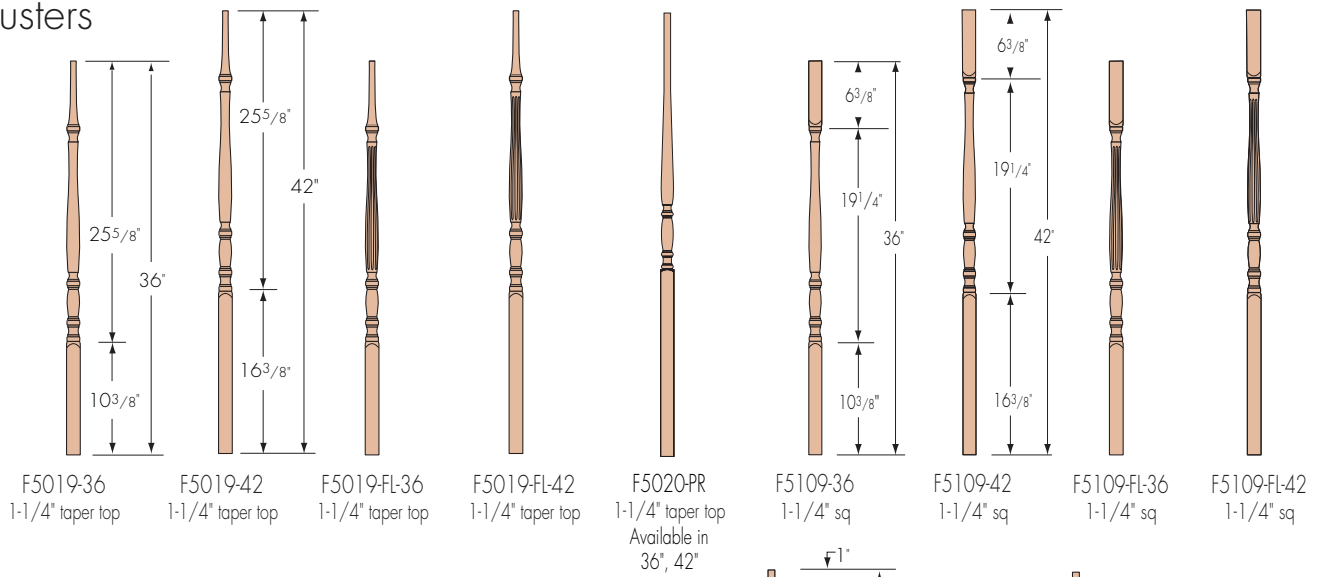

Newels

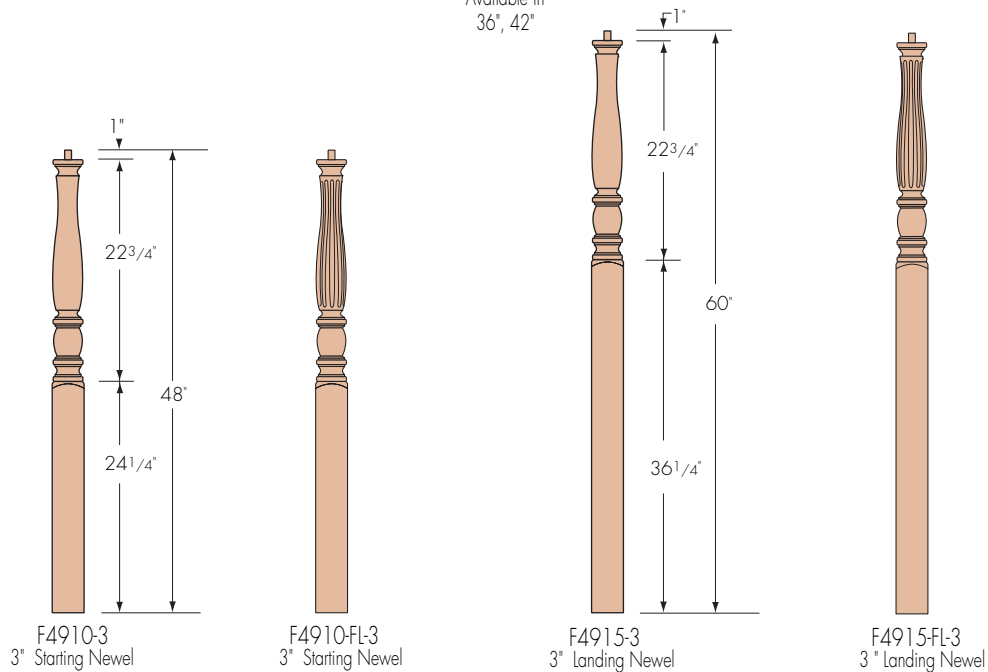

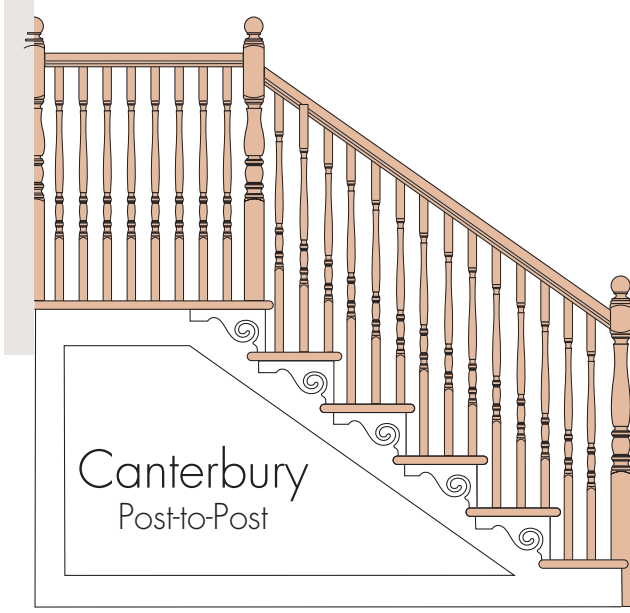

Handrail

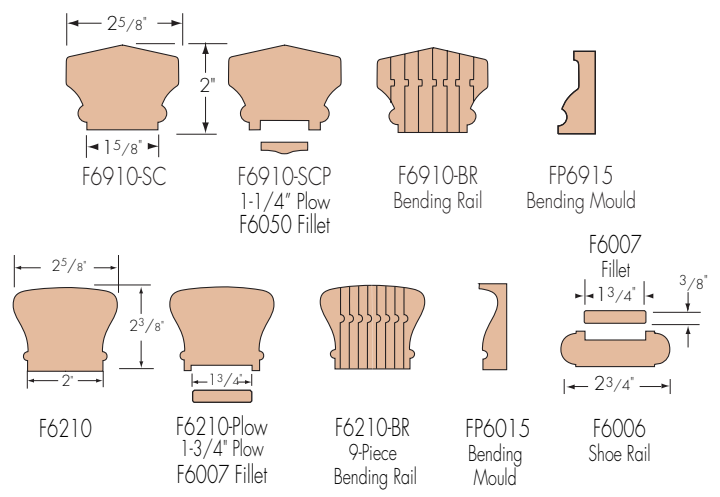

Balusters

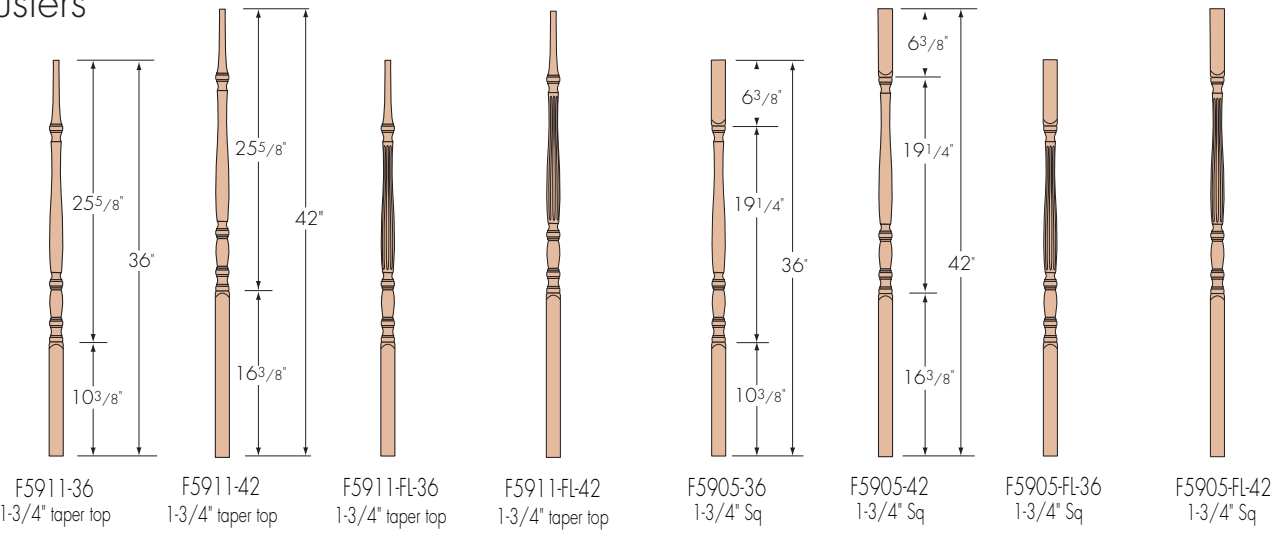

Newels

Specify "A" for Acorn Top

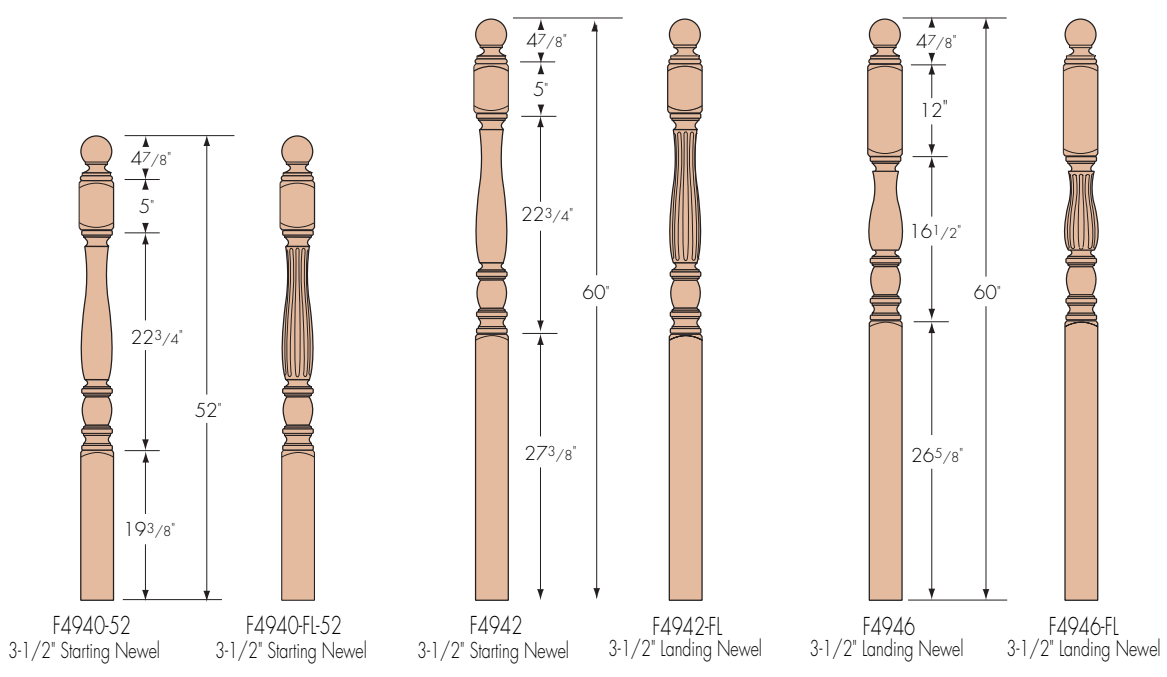

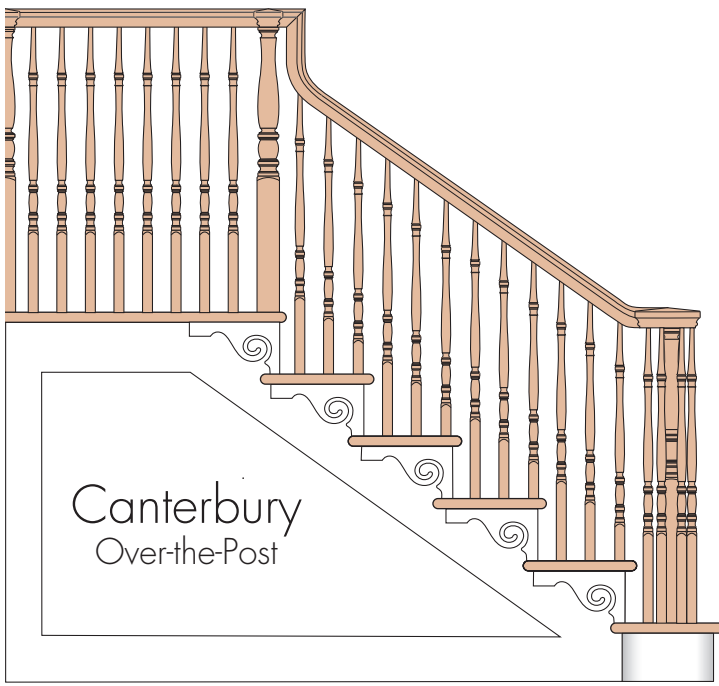

Handrail

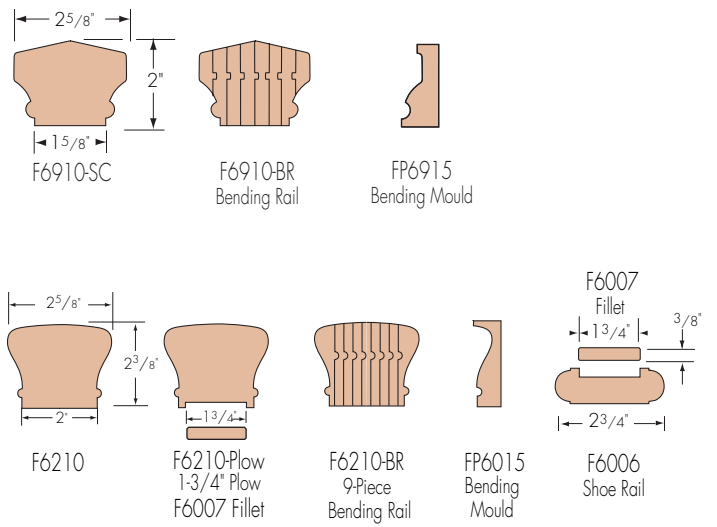

Balusters

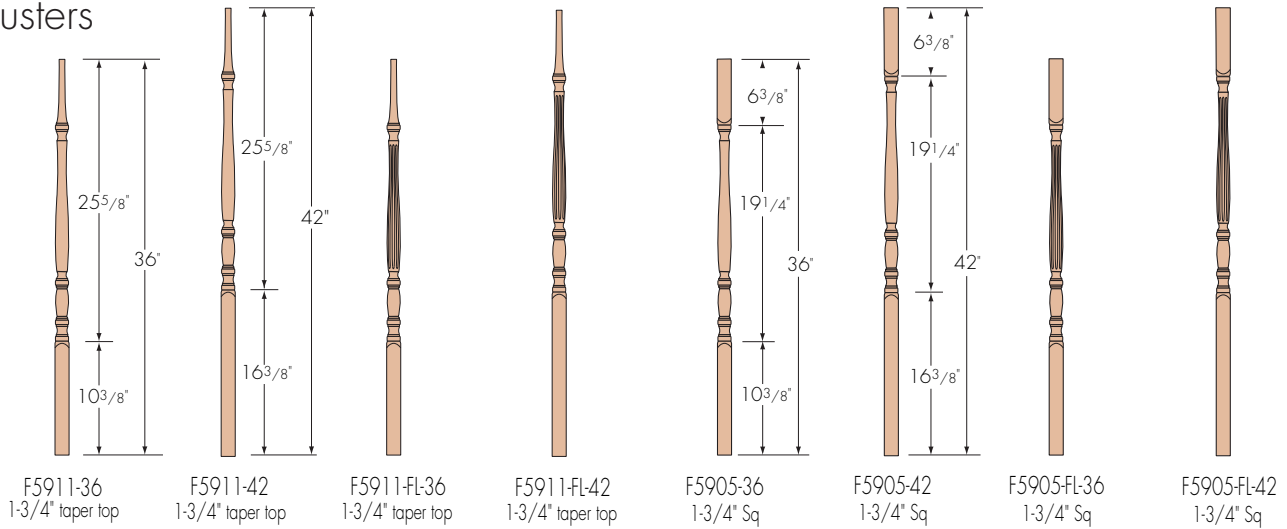

Newels

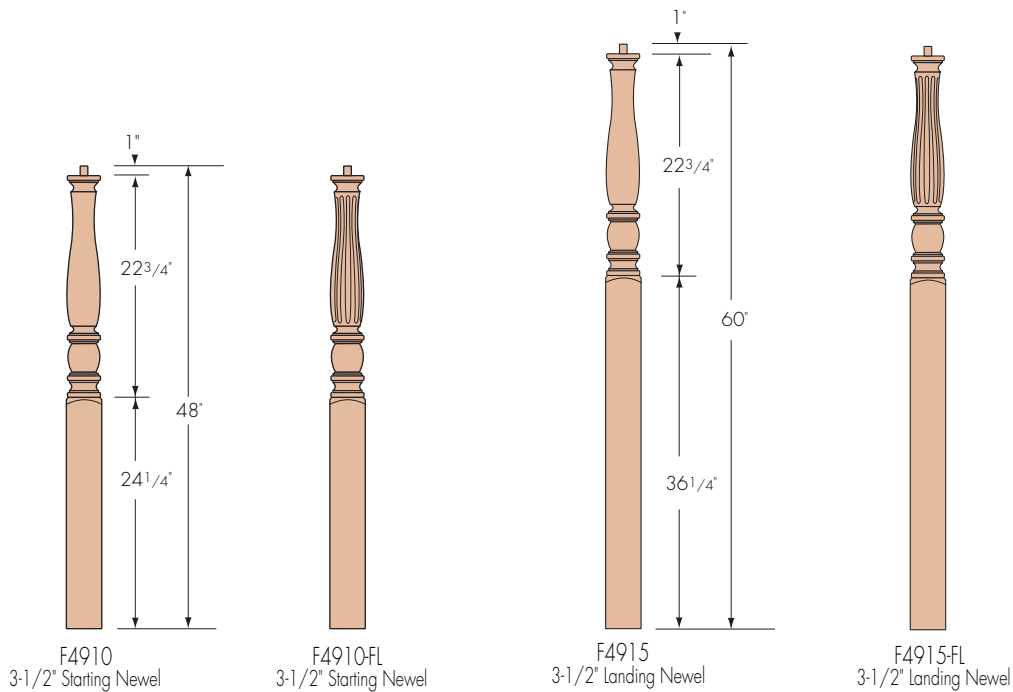

Hardwood Fittings

Matching Handrail/Fittings

To match to Fitts Industries, Inc. handrail profiles to Fitts Industries, Inc. fittings, simply key off of the second digit of the handrail profile and the last two digits of the fitting part number

F6010 Handrail = F70__ Fitting

F6210 Handrail = F72__ Fitting

F6910 Handrail = F79__ Fitting

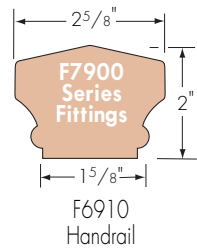
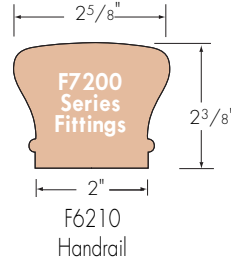
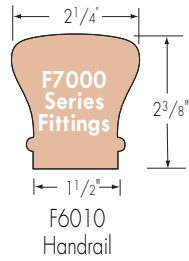

Starting Fittings

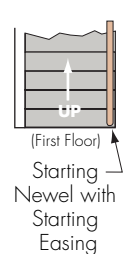
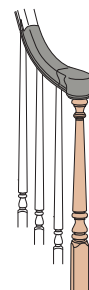
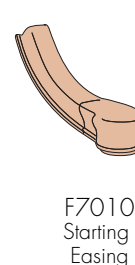
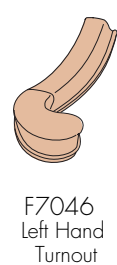
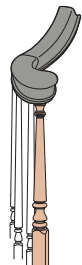
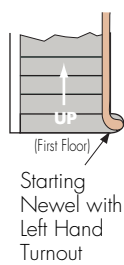
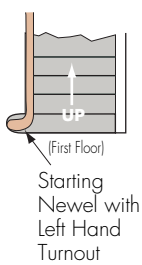
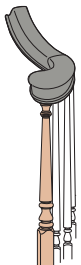
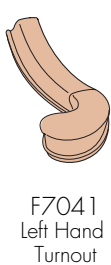
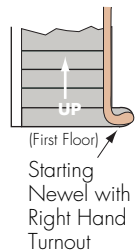
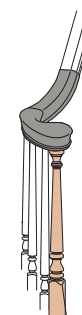
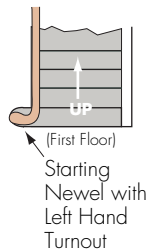
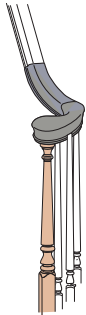
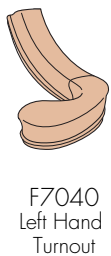
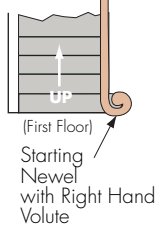
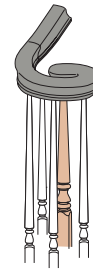
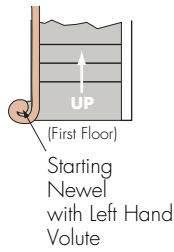
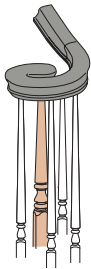
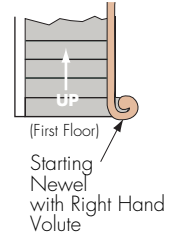
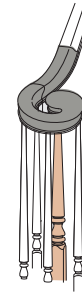
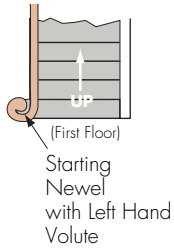
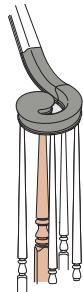

Transitional Fittings

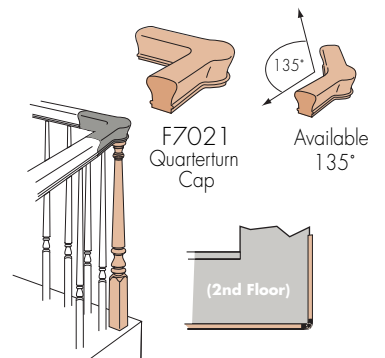
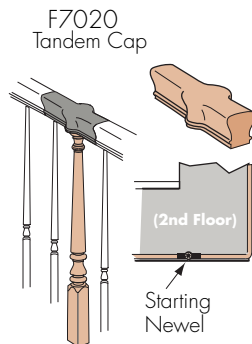
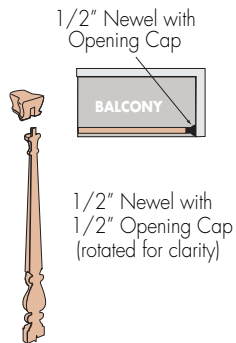
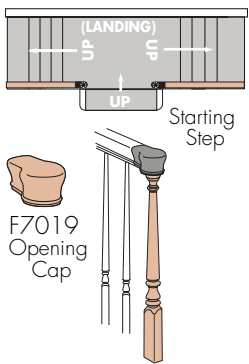
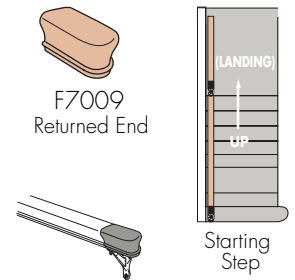
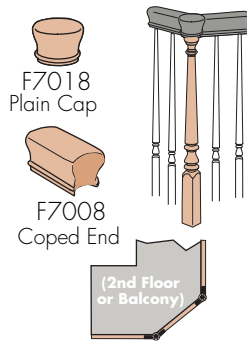
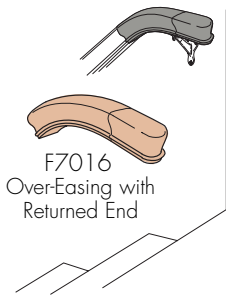
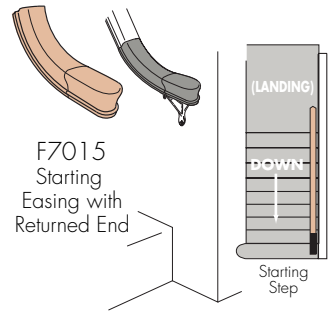
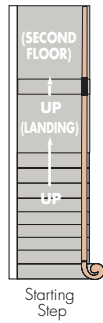
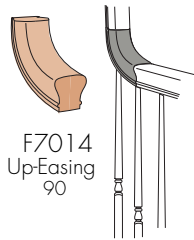
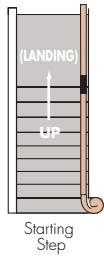
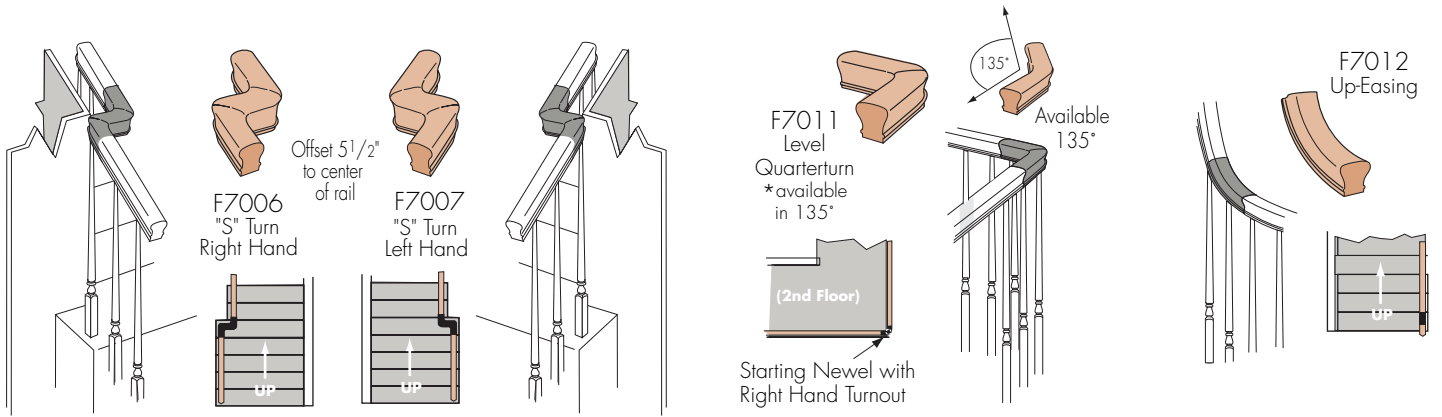

Gooseneck Fittings

*Note: For increased stability, the use of a newel under all Gooseneck Fittings is strongly recommended.

*On 2-rise Goosenecks bottom Up-Easing is unattached for adjustment in the field.



F7050
Left Hand
2-Rise
No Cap

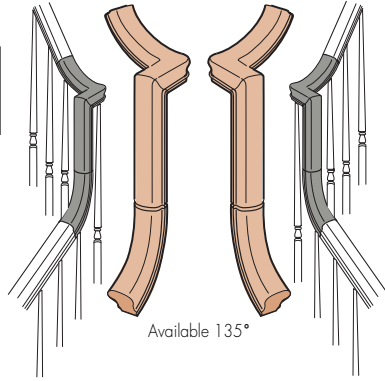

Available 135°



F7055
Right Hand
2-Rise
No Cap



Newel
F7060
Left Hand
2-Rise
with Cap

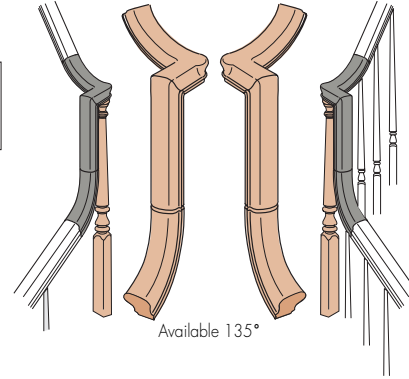

Available 135°



Newel
F7065
Right Hand
2-Rise
with Cap



F7071
Left Hand
2-Rise
no Cap

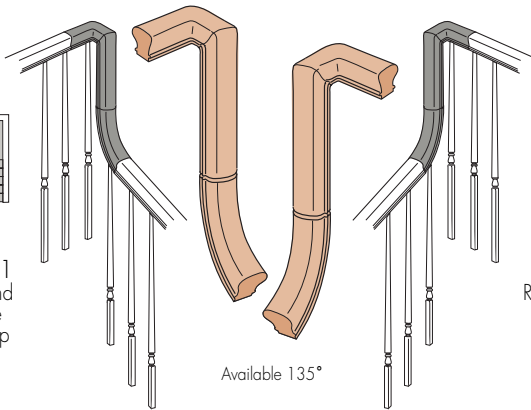

Available 135°



F7076
Right Hand
2-Rise
no Cap



Newel
F7081
Left Hand
2-Rise
with Cap

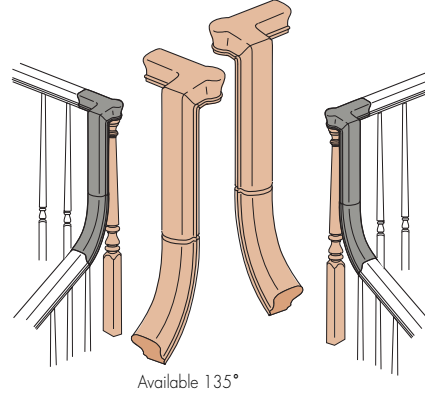

Available 135°



Newel
F7086
Right Hand
2-Rise
with Cap

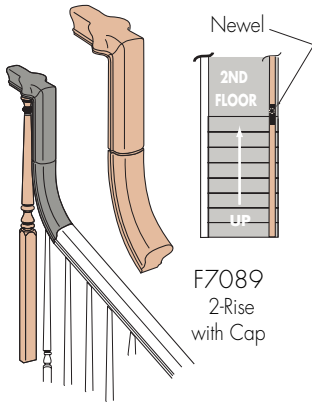

F7089
2-Rise
with Cap

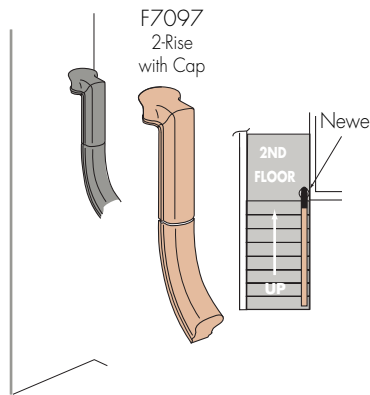

F7097
2-Rise
with Cap

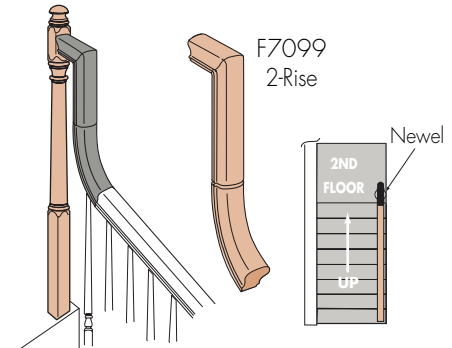

F7099
2-Rise

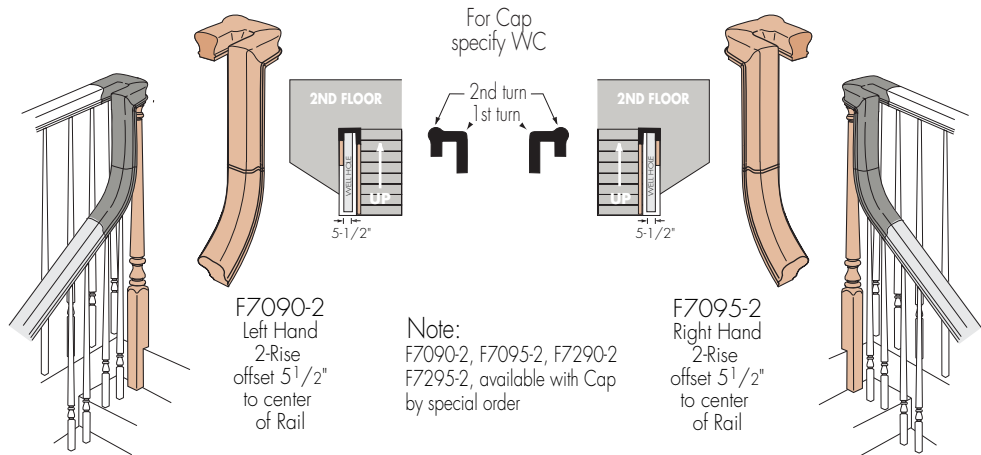

F7090-2
Left Hand
2-Rise
offset 5 1/2"
to center
of Rail

Note:
F7090-2, F7095-2, F7290-2,
F7295-2, available with Cap
by special order

F7095-2
Right Hand
2-Rise
offset 5 1/2"
to center
of Rail

Treads, Risers, Starting Steps & Tread Caps

All Fitts Industries, Inc. Starting Steps Include:

- Radius Shoe and Cove Mould
- Straight Shoe & Cove Mould
- The Option to Specify Paint Grade or Stain Grade Risers
- Reversible Single Bullnose Treads

Specifications:

- Starting Step Tread – 1" x 11-1/32"
- Riser – 3/4" x 7" (Overall Rise 8" w/Tread)
- Widths – are specified to outside of finished stringers, taking into consideration skirt board, sheetrock and tread brackets, if applicable.

False End Starting Step

F8011 — Use with F6010 Handrail with Turnout or Volute when carpeting the stair.

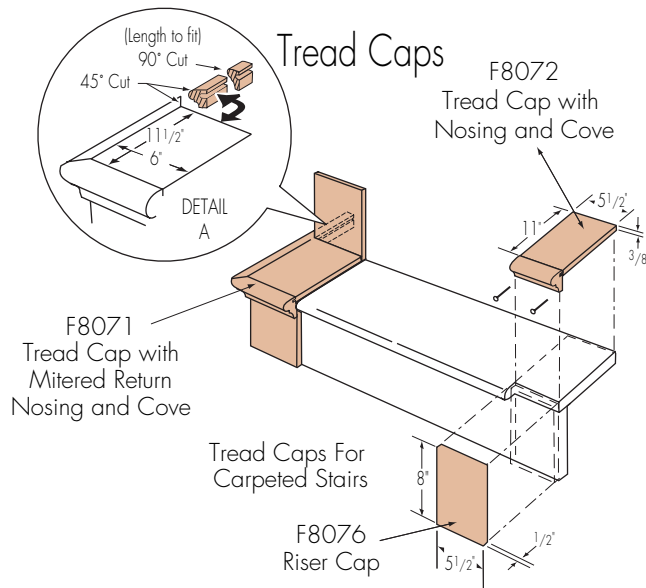
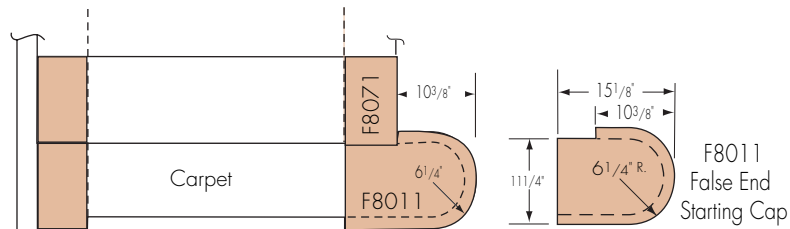

F8010 and F8015-48
Use with F6010 Handrail, with Turnout and Volutes.

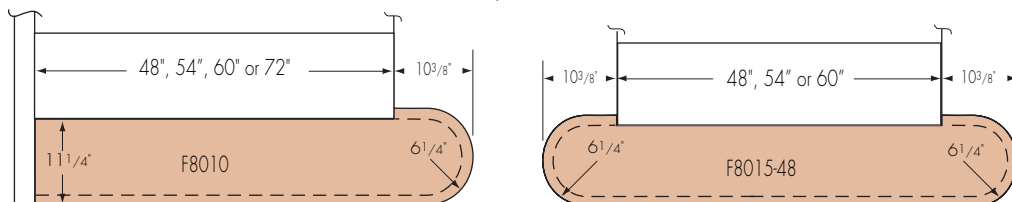

Treads, Risers, & Accessories

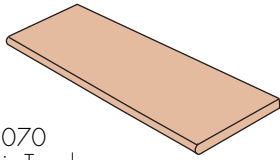

F8070
Plain Tread
1-1/32" x 10-1/2"
1-1/32" x 11-1/2"
Standard Lengths
36", 42", 48", 54", 60", 72"

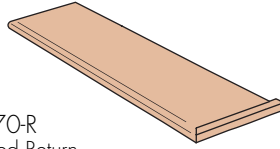

F8070-R
Mitered Return
1-1/32" x 10-1/2"
1-1/32" x 11-1/2"
Standard Lengths
36", 42", 48", 54", 60", 72"

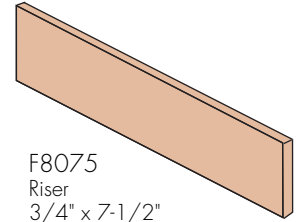

F8075
Riser
3/4" x 7-1/2"
3/4" x 8"
Standard Lengths
36", 42", 48", 54", 60", 72"

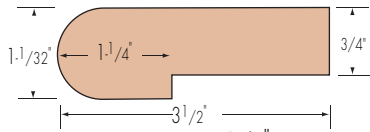

F8090-3 1/2"
Landing Tread
3-1/2" - 5-1/4"
Random Length

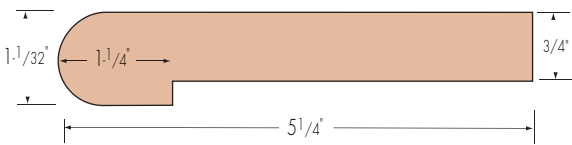

F8090-5 1/4"

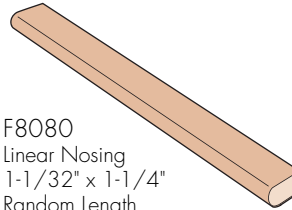

F8080
Linear Nosing
1-1/32" x 1-1/4"
Random Length
Nosing

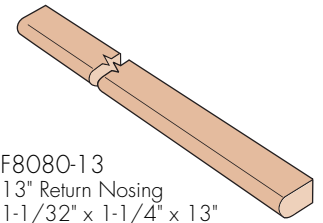

F8080-13
13" Return Nosing
1-1/32" x 1-1/4" x 13"
Nosed 1-Edge

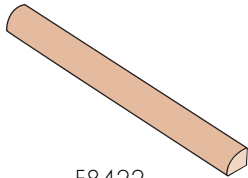

F8422
Shoe Mould
1/2" x 3/4"
Random Length

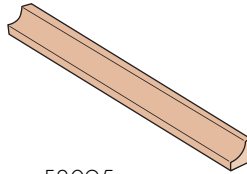

F8095
Cove Mould
3/4" x 3/4"
Random Length

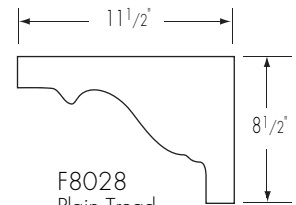

F8028
Plain Tread
Bracket
5/16" Thick

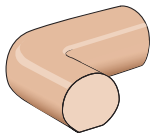

F7023
Quarterturn

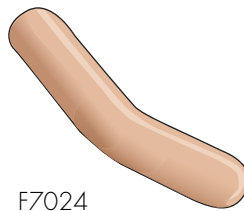

F7024
Starting Easing

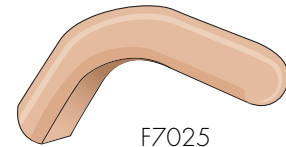

F7025
Over Easing

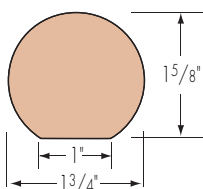

F6040
Wall Rail

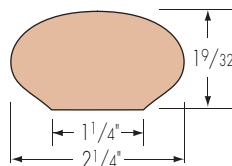

F6042
Wall Rail

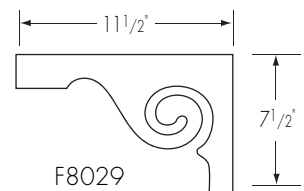

F8029
Scroll Tread
Bracket
5/16" Thick

Accessories



F3002
Brass



F3002-AB
Antique Brass



F3002-BL
Black



F3010-BN
Brushed Nickel
Center Mount



F3010-BC
Brushed Chrome
Center Mount



F3010-AB
Antique Brass
Center Mount



F3010
Brass
Tri - Mount



F3016 - BC
Brushed Chrome
Tri - Mount

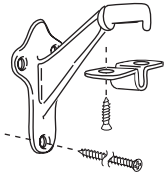

F3002
Tri - Mount
Wall Rail
Bracket

F3010-BK/BC/AB
Center Mount
Wall Rail Bracket

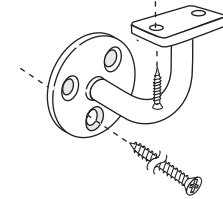
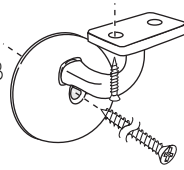

F3010
Tri-Mount
Wall Bracket
Solid Brass

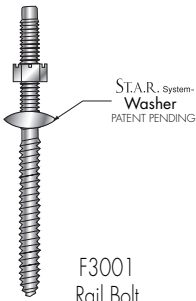

F3001
Rail Bolt
(enlarged for clarity)

F3000
Rail Plug



F3004
Clamp
Nail

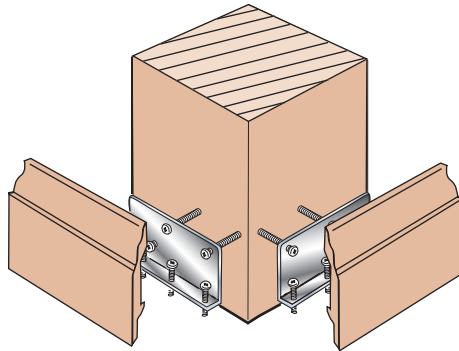

L-Anchor
Newel Fastener

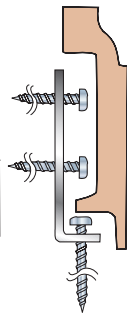

F3007-3"
F3008-3 1/2"

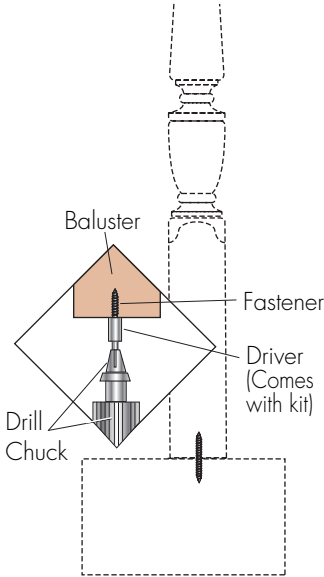

F3009
Baluster
Fastener
Driver



F3003
Baluster
Fastener
(No Driver)

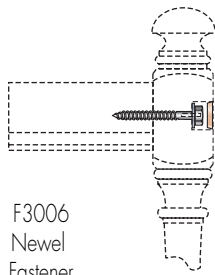

F3006
Newel
Fastener

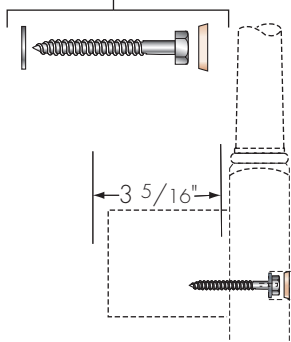

3 5/16"

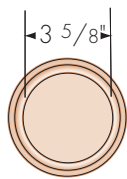

F7017
Step Detail

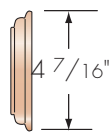

4 7/16"

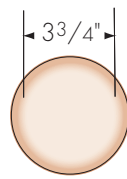

F7317
Eased Edge

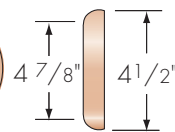

4 7/8"

4 1/2"

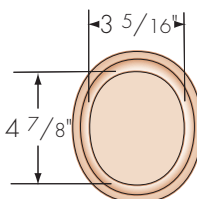

F7037
Step Detail

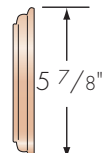

4 7/8"

5 7/8"

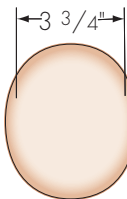

F7337
Eased Edge

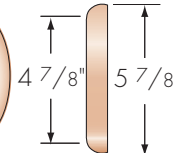

4 7/8"

5 7/8"

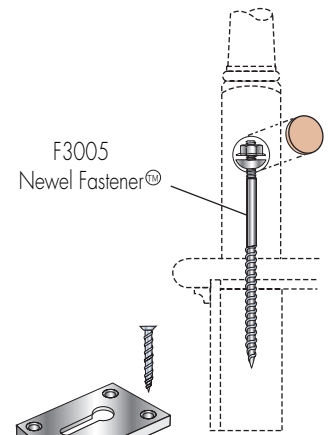

F3005
Newel Fastener™

F3015
Key Lock Newel Fastener™

Repetitive Specials

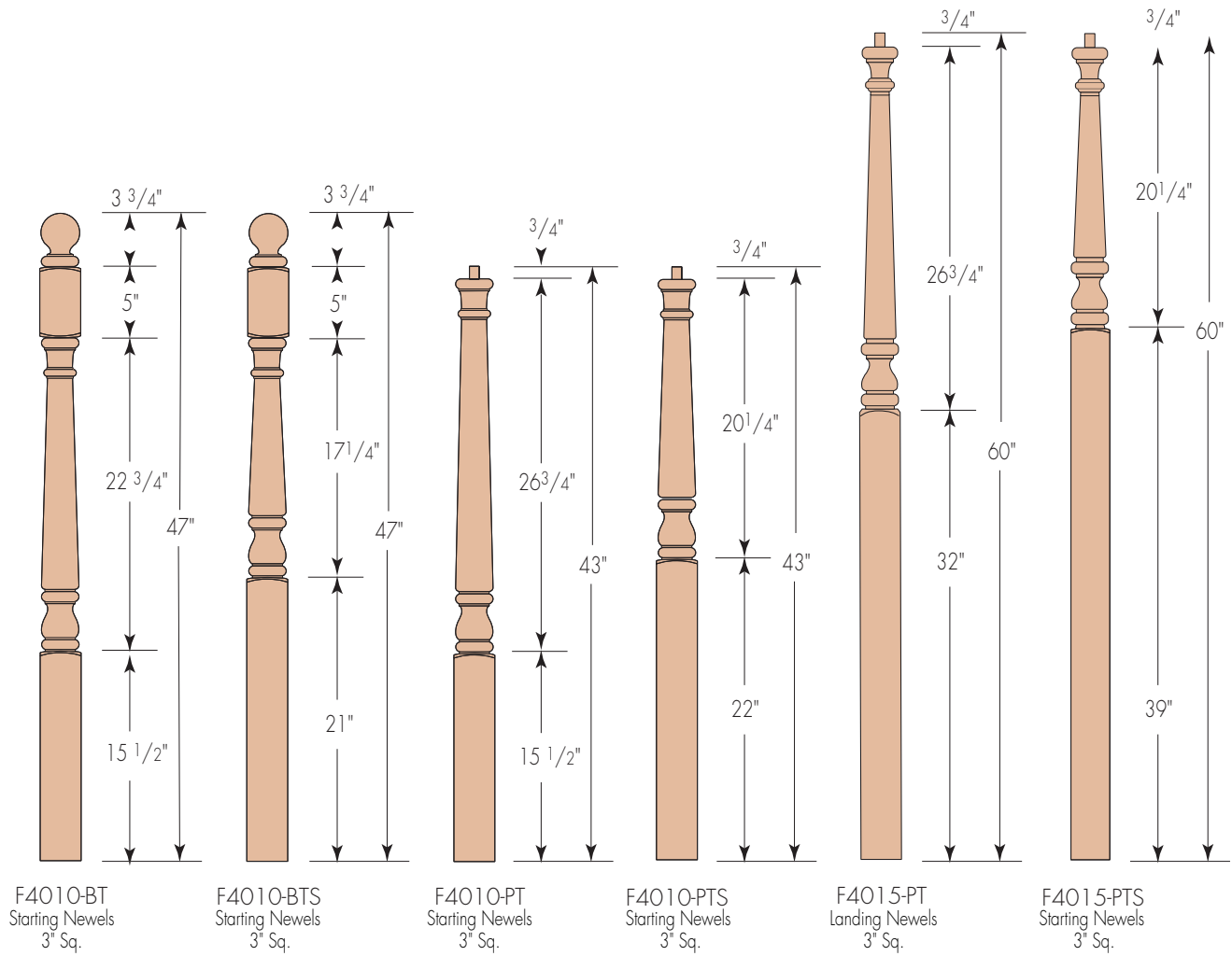

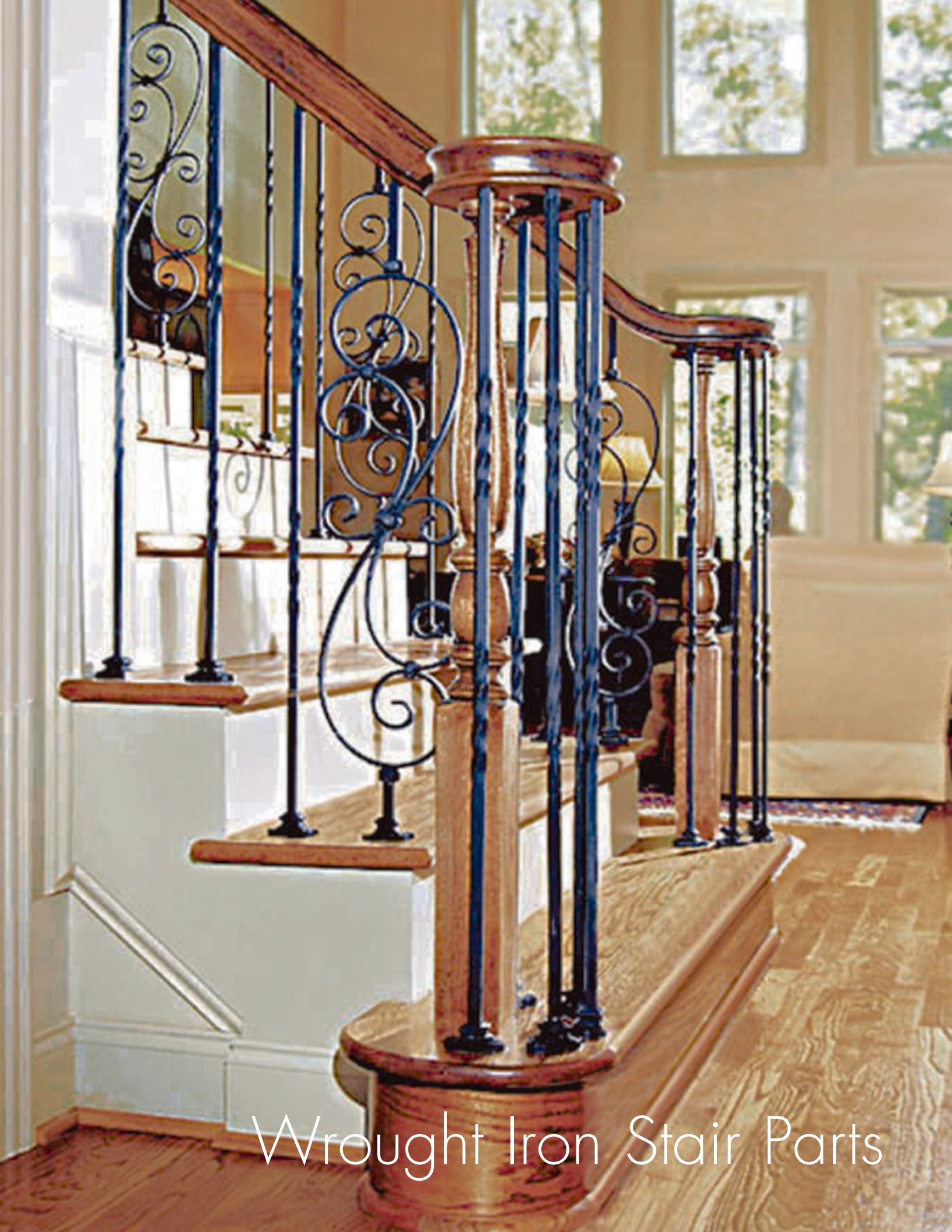

Wrought Iron Stair Parts

European Style & Elegance



Cover photo and photo above furnished by
Horner Millwork, Somerset, Mass.

Product Finishes

Five Elegant Finish Styles
From Which to Choose

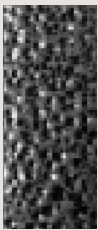

Silver
Black



Flat
Black



Antique
Bronze



Oil Rubbed
Bronze

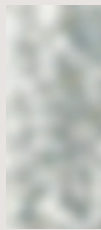

Antique
Nickel

For centuries, artisans have hammered and formed wrought iron. Through the ages blacksmiths mastered their trade to create ornate designs that became a staple of European style and elegance.

Frequently Asked Questions

Can I Paint Wrought Iron Product?

Yes, you can. For interior use, we suggest using one or two coats of lacquer or oil based paint for metal.

Can I Use Wrought Iron Product for Exterior Applications?

Yes, you can. For exterior use we suggest using two coats of exterior, oil based, metal paint for protection from the elements. We suggest not mounting wrought iron into concrete or brick. These substances are porous and trap water which can corrode iron product over time.

How Do I Cut or Trim Wrought Iron Products?

We suggest the use of a band saw with a metal cutting blade, but any metal cutting saw will work.

Can I Replace My Wood Balusters with Wrought Iron and Still Use the Same Piece of Handrail?

This is a bit tricky. In most cases - we say no. The layout of the balusters is going to differ. Due to code issues like sphere rules, and the design of the balusters you select, layouts are going to differ - as will the holes needed to be bored in the handrail.

Balusters are 1/2 inch or 9/16 inch respectively, and come in a 44 inch length. (Balusters are trimmed from the bottom to maintain the consistency of the pattern according to the rake of the stair.)

All Fitts Industries, Inc. balusters come with a 1/2 inch round pin top for easy installation in wood handrail.

New from Fitts Industries, Inc.
Box Newels with Wrought Iron Inlays

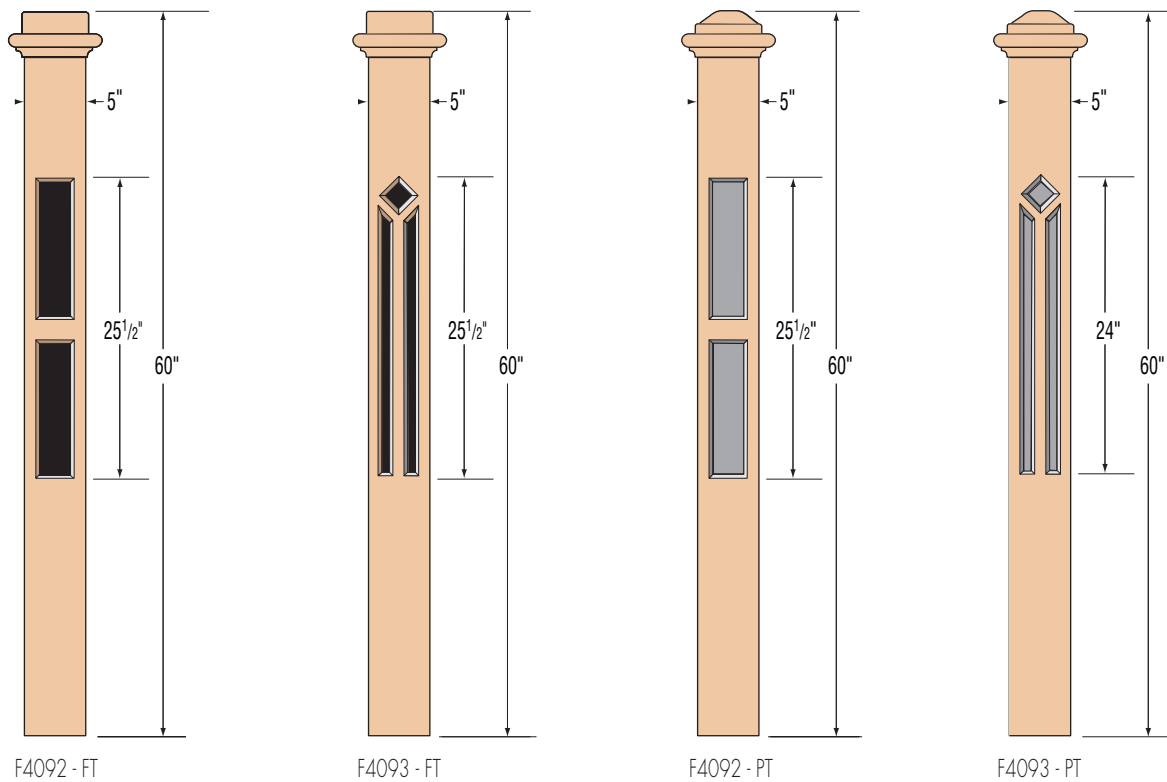

Fitts Industries, Inc, introduces an elegant series of Arts and Crafts Style Wrought Iron Inlay Box Newels. Iron Inlay Box Newels are manufactured in Red Oak and Hard Maple and have two options of caps — Fitts' standard box newel cap or Fitts' new pyramid cap.

Iron Balusters

1/2 inch Balusters

Monte Carlo
Bordeaux

1/2" Dia. Pin Top

F5518-44 (1/2")

F5519-44 (1/2")

F5500-44 (9/16")

F5501-44 (1/2")

F5502-34 (1/2")
 Knee Wall Scroll Application

F15511-44

F15512-44

F15515-44

F15516-44

1/2" Sq. Base (Typical all 1/2" balusters)

For 1/2" Balusters use:

F13101 Shoe

F13102 Pitch Shoe
 for Knee Wall Installation

F13104 Shoe
 w/screws

F13103 Adjustable
 Knuckle

Provance
Versailles

1/2" Dia. Pin Top

F15521-44

F15522-44

F15525-44

F15526-44

F15523-44

F15524-44

F15560-44

F15563-42*

F15560-44 (1) Adjustable knuckle F13103
 F15561-44 (Welded knuckle also available)

F15560-44 (2) Adjustable knuckles F13103
 F15562-44 (Welded knuckle also available)

1/2" Sq. Top

1/2" Sq. Base (Typical all 1/2" balusters)

Iron Balusters

1/2 inch Balusters

Burgundy Round

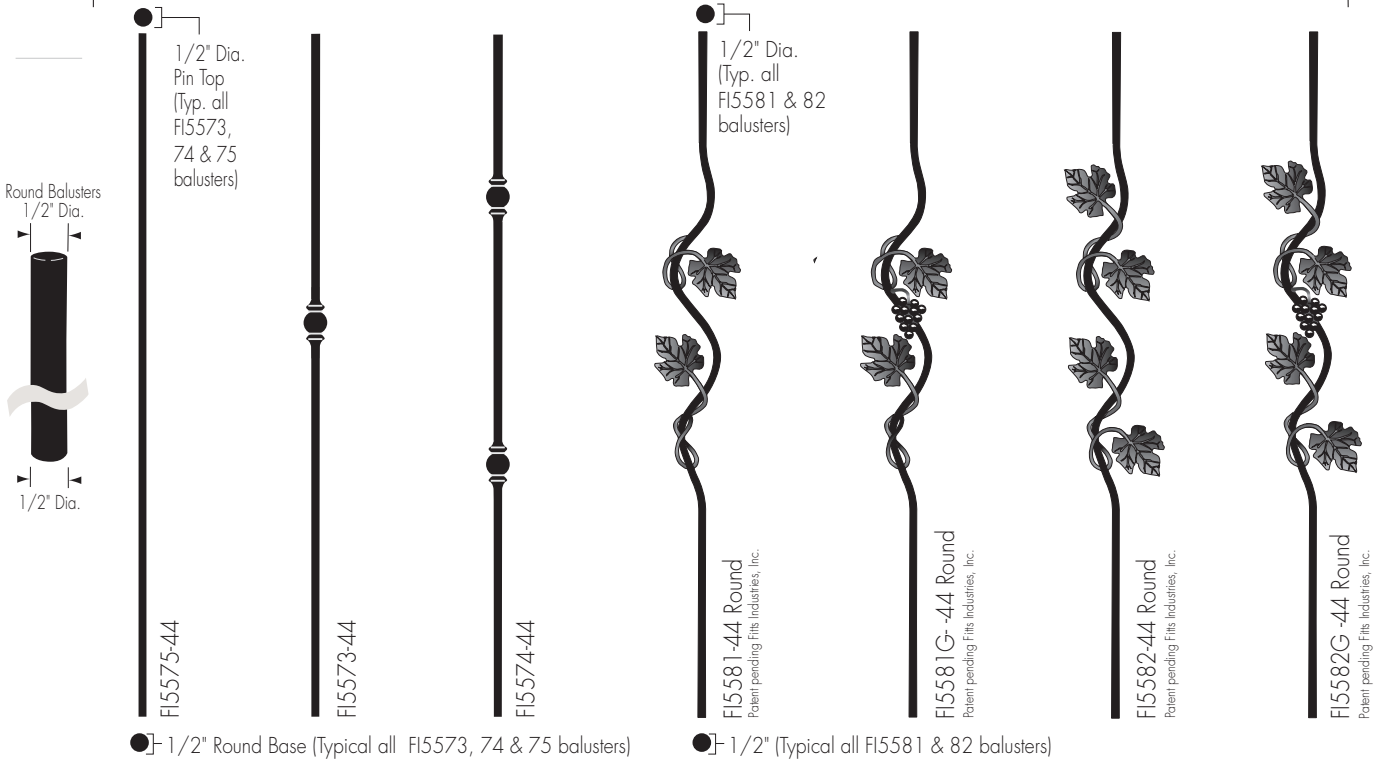

For 1/2" Round Balusters use:

For 9/16" Balusters use:



9/16 inch Balusters

Tavistock

Not designed for Knee Wall Applications



Burgundy



Phoenix

Not designed for Knee Wall Applications

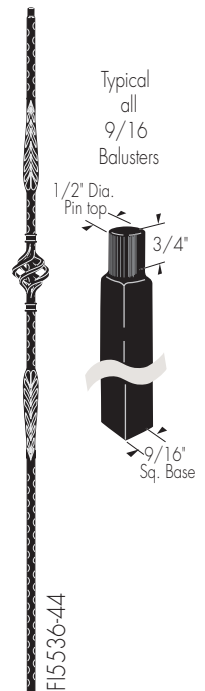

9/16" Sq. Base (Typical all 9/16" balusters)

9/16" Sq. Base (Typical all 9/16" balusters)

Quick Installation Reference



Step 1. Bore 5/8 inch holes in tread to accept the baluster bases.



Step 2. Cut baluster bases to height using a saw with a metal cutting blade and insert bases into tread.



Step 3. Using the epoxy with a hardening agent, fill the hole surrounding the baluster.

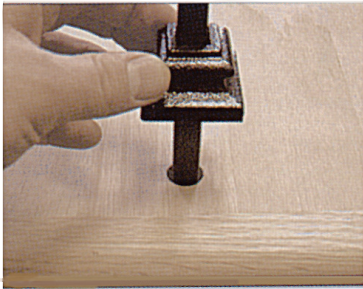

Step 4. Drop corresponding 1/2 inch or 9/16 inch shoe over baluster.

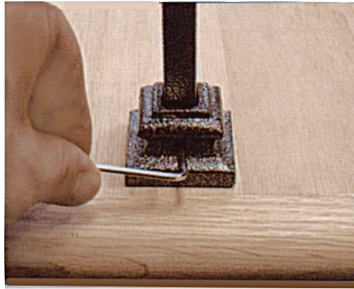

Step 5. Tighten the shoe to the baluster using a hex wrench.

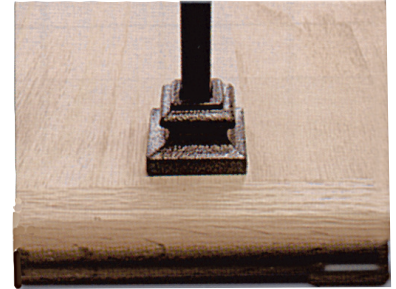

Step 6. Repeat on remaining balusters.



Step 7. All Fitts Industries, Inc. iron balusters come with a 1/2 inch diameter pin. Bore 1/2 inch holes in the handrail to accept baluster pins.

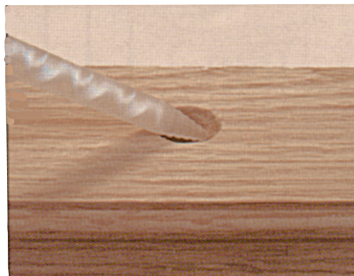

Step 8. Apply epoxy to all holes, limiting amount slightly to guard against runoff or dripping.



Step 9. Place rail onto corresponding balusters. Fit should be snug. If needed lay a scrap softwood block on the rail and gently tap into place with a wooden mallet.

Iron Newels, Shoes, Knuckles & Handrail

Newels

3/4" Dia. Pin Top (Typical all 1-1/8" Sq. Newels shown)



F411-48 Bordeaux

F415-48 Bordeaux

F412-48 Provance

F414-48 Tavistock

1-1/8" Sq. Base (Typical all Newels shown)

Shoes / Knuckles for Square Balusters



F3101 1/2 inch shoe
F3101-2 9/16 inch shoe



F3104 1/2 inch shoe
F3104-2 9/16 inch shoe



F3102 1/2 inch pitch shoe
F3102-2 9/16 inch pitch shoe



F3103 adjustable
1/2 inch knuckle

Shoes for Round Balusters



F3101-5 1/2"
Round Shoe



F3102-5 1/2"
Round Pitch Shoe



F3104 1/2"
Round Shoe
w/screws

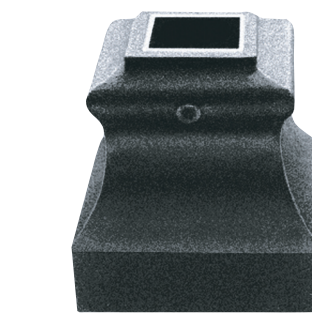

F3400 Newel attachment and
shoe with screws and wrench

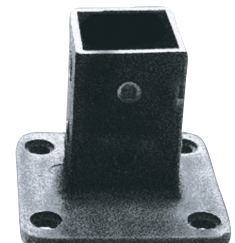

F3200-NZ

F3200-EF

F3200

F3200-NZ Nozzle
Designed to distribute
a 1:1 Mixture

F3200-EF Two Part Epoxy
and hardening agent
(Quick Dry Epoxy-10-15
Contact Points)

F3200 Epoxy gun

Handrail

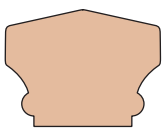

F6910

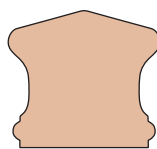

F6710

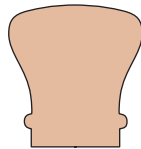

F6010

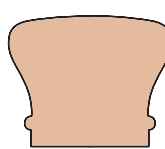

F6210

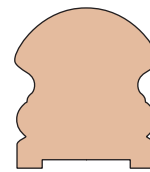

F6019

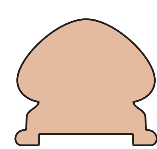

F6005

Stair Take-Off Quick Reference

With more than 3000 parts, pieces & profiles, selection and ordering stair parts can be intimidating. To begin the process, ask yourself a few simple questions:

1. **Is the stair Post-to-Post or Over-the-Post?**
2. **What style of stair parts will match the architectural theme of the home?**
3. **What species of wood will match the continuity of the home?**
4. **What are my concerns relating to building codes?**

Fitts Industries, Inc. has alleviated some of this guesswork for you. All of the newel heights, baluster heights, and most of the handrail profiles will fall within the IRC 2003 building code requirements with regards to stairs. It is however, important that you familiarize yourself with codes regarding stair building in your locality.

As far as compiling a list of what you will need, there are several important components you will want to pay attention to:

- **Starting Steps** - Starting steps are the decorative first step of a stair. With elongated ends that imitate a bull's nose - bullnose starting steps often support volute or turnout newels, and volute or turnout fittings. The important measurement of a single or a double bullnose is the dimension of the finished stringers + skirtboard + sheetrock.
- **Treads** - Form the stepping surface of the stair. Treads are often open sided with returned ends or unfinished and set between a series of knee walls.
- **Risers** - The vertical face of a stair step.
- **Handrail** - Handrail is the top rail used in a balustrade system; it provides gripping surface for support. Handrail is either straight or bending for radius curves. Handrail comes in a variety of profiles, and most of the profiles offer fittings to provide Over-the-Post systems.
- **Moulding & Brackets** - Ornamental brackets and moulding can be added to the undersides of the treads or tread returns.
- **Attaching Hardware** - All Fitts Industries, Inc. fittings come with rail bolts for the necessary connection points. You will need to determine what method of connection you will use on your newel posts, and order the proper hardware for each post. Note that most Fitts Industries, Inc. balusters come with a dowel pin for installation in the tread.

The next several pages will discuss **newel posts, balusters, and fittings** - followed by a series of tables depicting **baluster length structures**. Please be aware all of Fitts Industries, Inc. newel heights and balusters work off of a 34-38" rake rail height.

Newel Selection

After you have determined the species of wood you are going to use for your staircase, and decided whether the stair is going to be carpeted, most people select the newel profile they will use throughout the stair. To get the basics, in a classic L-shaped stair with a landing there are three newel variations you will use:

Starting Newel Post-to-Post

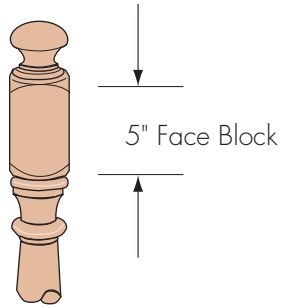

Over-the-Post

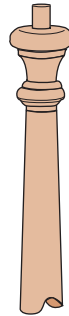

Pin Top Newel

Starting Newel – Starting Easing
Volute Newel – Volute
Turnout Newel – Turnout

Intermediate Newel Post-to-Post

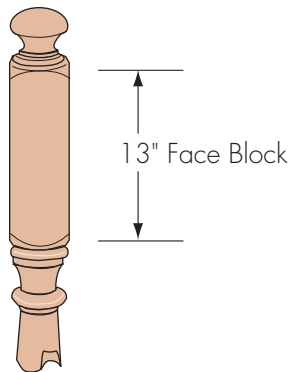

Over-the-Post

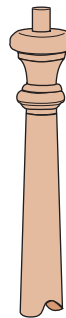

Pin Top Landing Newel

Accepts Transition Fittings

Landing Newel Post-to-Post

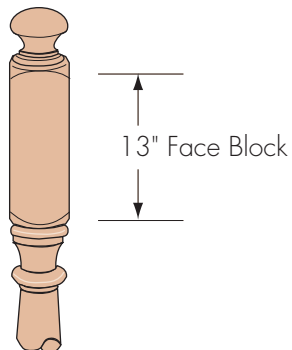

Over-the-Post

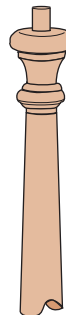

Pin Top Landing Newel

Accepts Gooseneck
Fittings

Baluster Selection

Fitts Industries, Inc. balusters have been designed in families, so that each newel pattern has one or more corresponding baluster turnings that work in conjunction with the newels. Most questions arise with what baluster length structure to use. Fitts Industries, Inc. has developed rake rail height – with the patterns that will not only pass with building codes 4-inch sphere rule, but will maintain architectural alignment throughout the stair.

Balusters were often aligned as either:

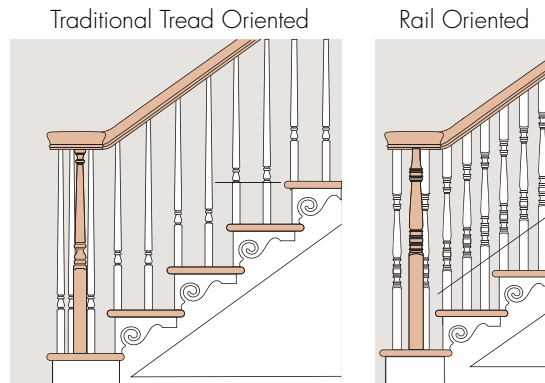

In many cases, the 6-inch sphere rule was minimized to a 4-inch sphere rule, certain systems changed from a two baluster per tread to a three baluster per tread layout. Geometrically, this changed the way the patterns would work in a Rail Oriented System. So, in June of 2001 Fitts Industries, Inc. began altering length structures so that we could provide an architecturally correct alternative for those customers who prefer Tread Oriented Systems.

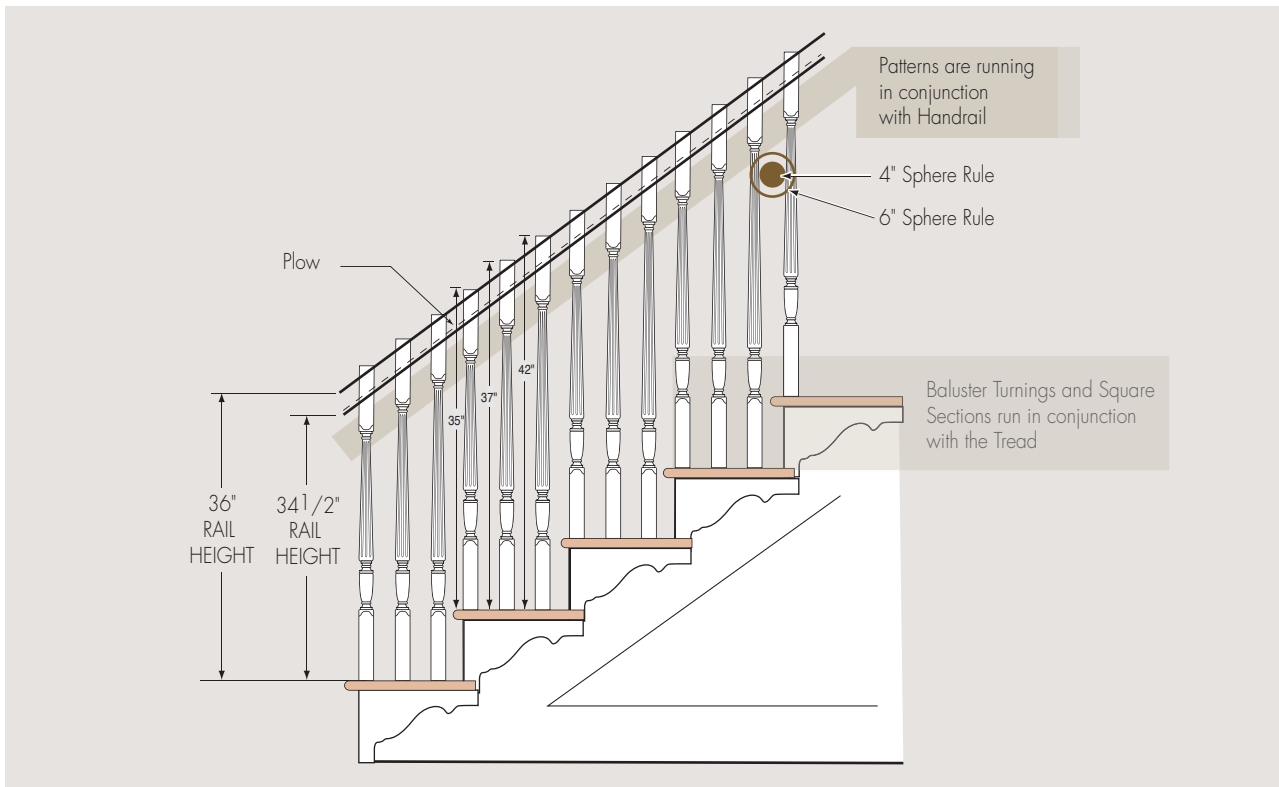

A simplified table of baluster & newel options can be found on pages 52-57.

Fitting Selection

Fittings are designed to provide the necessary changes in rake angles in handrail and provide a continuous gripping surface throughout the stair. Fitts Industries, Inc. offers fittings in three handrail profiles: F6010, F6210, F6310, F6910 and F6410. Fittings are designed in three major families:

- Starting Fittings – The beginning of the rail gripping surface
- Transition Fittings – Fittings that are transitioning units of a rail surface
- Gooseneck Fittings – Fittings used to allow for transition in height and (or) direction in either a landing or a balcony

Fitting Characteristics

Right Hand or Left Hand – Fittings are determined to be Right Handed or Left Handed by the natural act of ascending or climbing the stair.

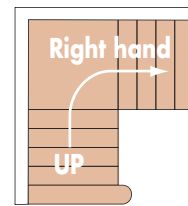
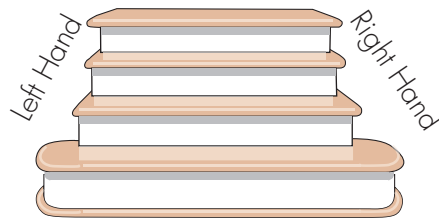
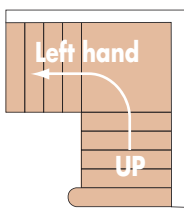

Fitting with Cap – Fittings that run over a newel post have a cap to accommodate the newel post.

F7021

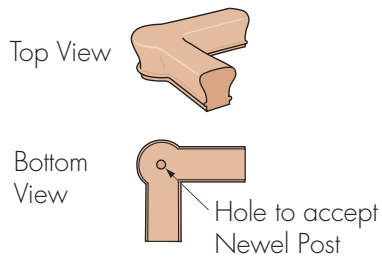

F7020

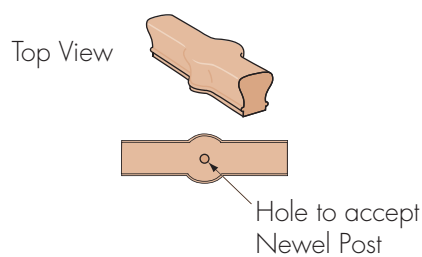

One Rise, Two Rise & Three Rise – In the transition of handrail, often times fittings must make changes in height and (or) direction. The easiest way to gauge the rise of a fitting is to note how many rises intersect at a transitioning or landing newel.

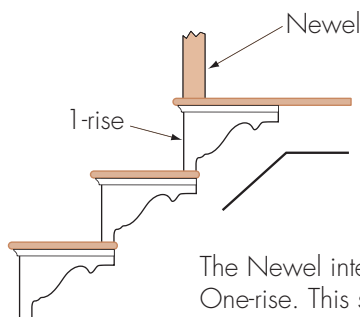

The Newel intersects with One-rise. This scenario would utilize a 1-rise Gooseneck.

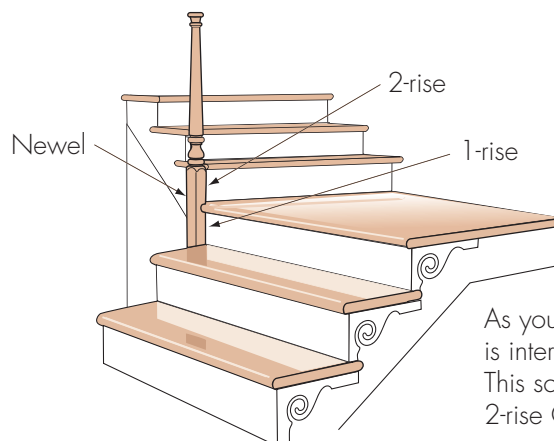

As you can see, the Newel is intersected by two rises. This scenario would utilize a 2-rise Gooseneck

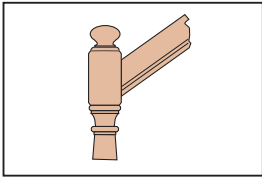

Hemlock Post-to-Post Suggested Newel & Baluster Components

These layouts are based on suggested families of stairparts with regards to IRC 2003 Building Codes.

Handrail can be selected with regards to its' proportional size or the necessity of a plow to accept square top balusters. (1-1/4" Balusters will require a 1-1/4" Plowed Handrail.)

Post-to-Post (Without Fittings) 34 - 38" Rake Rail Height

First Flight of Stairs (Classic L-Shaped Design)						
Hemlock	Newel		Baluster			
	Starting	Profile	Kneewall	1st Baluster	2nd Baluster	3rd Baluster (Opt.)
Traditional	FH4040	FH5015	31 or 34"	36	39	42
		FH5050	36	36	42	42
		FH5070	36	36	42	42
	FH4040-TT	FH5015	31 or 34"	36	39	42
		FH5050	36	36	42	42
		FH5070	36	36	42	42
Madison	FH3500	FH5610	36	39	42	42
		FH5105	36	36	42	42
Hampton	FH4500	FH5315	32	36	42	42
		FH5611	32	36	42	42
		FH5005	32	36	42	42
Olympia	FH4840	FH5802	32	36	42	42
Mission Style	FH4000-348	FH5060	36	36	42	42
		FH5060-CH	36	36	42	42
	FH4000-448	FH5360	36	36	42	42
	FH4000-CH-448	FH5360-CH	36	36	42	42
	FH4004	FH5360	36	36	42	42
	FH4104	FH5360	36	36	42	42
	FH4204	FH5360	36	36	42	42

34 - 38" Rake Rail Height

Second Flight of Stairs						
Hemlock	Newel		Baluster			
	Starting	Profile	Kneewall	1st Baluster	2nd Baluster	3rd Baluster (Opt.)
Traditional	FH4046-60	FH5015	31 or 34"	36	39	42
		FH5050	36	36	42	42
		FH5070	36	36	42	42
	FH4040-TT	FH5015	31 or 34"	36	39	42
		FH5050	36	36	42	42
		FH5070	36	36	42	42
Madison	FH3505	FH5610	36	36	42	42
		FH5105	36	36	42	42
Hampton	FH4505	FH5315	32	36	42	42
		FH5611	32	36	42	42
		FH5005	32	36	42	42
Olympia	FH4846	FH5802	32	36	42	42
Mission Style	FH4000-360	FH5060	36	36	42	42
		FH5060-CH	36	36	42	42
	FH4000-460	FH5360	36	36	42	42
	FH4000-CH-460	FH5360-CH	36	36	42	42
	FH4005	FH5360	36	36	42	42
	FH4105	FH5360	36	36	42	42
	FH4205	FH5360	36	36	42	42

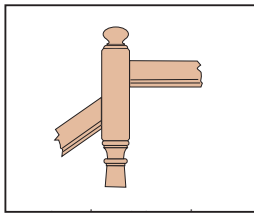

Hemlock

Post-to-Post Suggested Newel & Baluster Components (Continued)

Post-to-Post (Without Fittings)

34 - 38" Rake Rail Height

Balcony/Landing			
Hemlock	Newel	Baluster	Balcony
	Starting	Profile	
Traditional	FH4045 or FH4040	FH5015	42
		FH5050	42
		FH5070	42
	FH4040-TT	FH5015	42
		FH5050	42
		FH5070	42
Madison	FH3503	FH5610	42
		FH5105	42
Hampton	FH4505	FH5315	42
		FH5611	42
		FH5005	42
Olympia	FH4846	FH5802	42
Mission Style	FH4000-360	FH5060	42
		FH5060-CH	42
	FH4000-460	FH5360	42
		FH5360-CH	42
	FH4005	FH5360	42
	FH4105	FH5360	42
FH4205	FH5360	42	

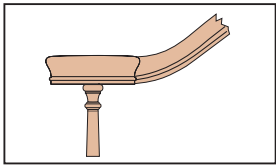

Hemlock

Over-the-Post Suggested Newel & Baluster Components (Continued)

Over-the-Post

34 - 38" Rake Rail Height

First Flight of Stairs (Classic L-Shaped Design)

Hemlock	Newel			Profile	Baluster		Baluster Placement		
	Starting	Volute	Turnout		Volute	Turnout	1st Baluster	2nd Baluster	3rd Baluster (Opt.)
Traditional	FH 4010	FH4013	FH4014	FH5015	42	42	36	39	42
	FH 4010	FH4013	FH4014	FH5050	42	42	36	42	42
	FH 4010	FH4013	FH4014	FH5070	42	42	36	42	42

FH4020 **Fitts Industries, Inc. offers a FH4020 as a Pin Top alternative for long rake sections

34 - 38" Rake Rail Height

Second Flight of Stairs

Hemlock	Newel		Baluster		
	Intermediate	Profile	1st Baluster	2nd Baluster	3rd Baluster (Opt.)
Traditional	FH4015	FH5015	36	39	42
		FH5050	36	42	42
		FH5070	36	42	42

34 - 38" Rake Rail Height

Second Flight of Stairs

Hemlock	Newel		Baluster	
	Intermediate	Profile		Balcony
Traditional	FH4015	FH5015		42
		FH5050		42
		FH5070		42

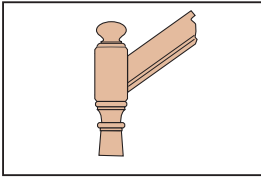

Hardwood Post-to-Post Suggested Newel & Baluster Components

These layouts are based on suggested families of stairparts with regards to IRC 2003 Building Codes.

Handrail can be selected with regards to its' proportional size or the necessity of a plow to accept square top balusters. (1-1/4" Balusters will require a 1-1/4" Plowed Handrail.)

Post-to-Post (Without Fittings)

34 - 38" Rake Rail Height

First Flight of Stairs (Classic L-Shaped Design)

Hardwood	Newel		Kneewall	Baluster		
	Starting	Profile		1st Baluster	2nd Baluster	3rd Baluster (Opt.)
Traditional	F4040	F5015	31 or 34"	36	39	42
	F4040	F5050		36	42	42
	F4040	F5070		36	39	42
Lexington	F4140	F5015	31 or 34"	36	39	42
	F4140	F5050		36	42	42
	F4140	F5070		36	39	42
	F4140	F5105		36	42	42
	F4140	F5610		36	42	42
Mission Style	F4090	F5060	36	36	42	42
	F4000/F4000-BT	F5360	36	36	42	42
	F4005	F5360	36	36	42	42
	F4091	F5360	36	36	42	42
Mini-Canterbury	F4940-3-52	F5019		36	42	42
	F4940-3-52	F5109		36	42	42
Canterbury	F4940-52	F5911		36	42	42
	F4940-52	F5905		36	42	42

Balcony (Classic L-Shaped Design)

Hardwood	Newel		Kneewall	Baluster		
	Starting	Profile		1st Baluster	2nd Baluster	3rd Baluster (Opt.)
Traditional	F4046	F5015	31 or 34"	36	39	42
	F4046	F5050		36	42	42
	F4046	F5070		36	39	42
Lexington	F4146	F5015	31 or 34"	36	39	42
	F4146	F5050		36	42	42
	F4146	F5070		36	39	42
	F4146	F5105		36	42	42
	F4146	F5610		36	42	42
Mission Style	F4090	F5060	36	36	42	42
	F4000/F4000-BT	F5360	36	36	42	42
	F4006	F5360	36	36	42	42
	F4091	F5360	36	36	42	42
Mini-Canterbury	F4946-3-52	F5019		36	42	42
	F4946-3-52	F5109		36	42	42
Canterbury	F4946-52	F5911		36	42	42
	F4946-52	F5905		36	42	42

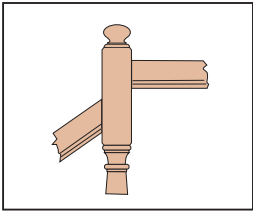

Hardwood Post-to-Post Suggested Newel & Baluster Components (Continued)

Post-to-Post (Without Fittings)

34 - 38" Rake Rail Height

Balcony			
Hardwood	Newel	Profile	Baluster
	Starting		
Traditional	F4042/45	F5015	42
	F4042/45	F5050	42
	F4042/45	F5070	42
Lexington	F4142	F5015	42
	F4142	F5050	42
	F4142	F5070	42
	F4142	F5105	42
	F4142	F5610	42
Mission Style	F4090	F5060	42
	F4001/F4001-BT	F5360	42
	F4005/06	F5360	42
	F4091	F5360	42
Mini-Canterbury	F4942-3-52	F5019	42
	F4942-3-52	F5109	42
Canterbury	F4942-52	F5911	42
	F4942-52	F5905	42

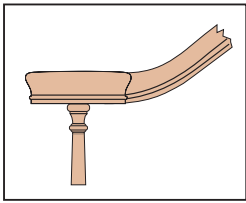

Hardwood Over-the-Post Suggested Newel & Baluster Components

These layouts are based on suggested families of stairparts with regards to IRC 2003 Building Codes.

Handrail can be selected with regards to its' proportional size or the necessity of a plow to accept square top balusters. (1-1/4" Balusters will require a 1-1/4" Plowed Handrail.)

Over-the-Post

34 - 38" Rake Rail Height

First Flight of Stairs (Classic L-Shaped Design)

Hardwood	Newel			Baluster			Baluster Placement		
	Starting	Volute	Turnout	Profile	Volute	Turnout	1st Baluster	2nd Baluster	3rd Baluster (Opt.)
Traditional	F4010-48	F4013	F4014	F5015	42	42	36	39	42
	F4010-48	F4013	F4014	F5050	42	42	36	42	42
	F4010-48	F4013	F4014	F5070	42	42	36	42	42
Hampton	F4210-48	F4210	F4210	F5611	42	42	36	42	42
	F4210-48	F4210	F4210	F5005	42	42	36	42	42
Mini-Canterbury	F4910-3	F4910-3	F4910-3	F5019	42	42	36	42	42
	F4910-3	F4910-3	F4910-3	F5109	42	42	36	42	42
Canterbury	F4910	F4910	F4910	F5911	42	42	36	42	42
	F4910	F4910	F4910	F5905	42	42	36	42	42

F4020 & F4220 **Fitts Industries, Inc. offers a FH4020 as a Pin Top Alternative for long rake sections

34 - 38" Rake Rail Height

Second Flight of Stairs

Hardwood	Newel	Baluster			
	Intermediate	Profile	1st Baluster	2nd Baluster	3rd Baluster (Opt.)
Traditional	F4015	F5015	36	39	42
	F4015	F5050	36	42	42
	F4015	F5070	36	42	42
Hampton	F4215	F5611	36	42	42
	F4215	F5005	36	42	42
Mini-Canterbury	F4915-3	F5019	36	42	42
	F4915-3	F5109	36	42	42
Canterbury	F4915	F5911	36	42	42
	F4915	F5905	36	42	42

34 - 38" Rake Rail Height

Balcony

Hardwood	Newel	Baluster	
	Balcony	Profile	Balcony
Traditional	F4010-48	F5015	42
	F4010-48	F5050	42
	F4010-48	F5070	42
Hampton	F4210-48	F5611	42
	F4210-48	F5005	42
Mini-Canterbury	F4910-3	F5019	42
	F4910-3	F5109	42
Canterbury	F4910	F5911	42
	F4910	F5905	42

Architectural Stair Designs



Pictured: F6910-Oak Handrail • F4942-Oak Newels • FP5911-Paint Grade Balusters • F8090-5 1/4 Oak Landing Tread

Downloadable CAD Detail

www.fitts.com

Architects and Specifiers alike—please visit Fitts Industries', Inc. interactive website to download more than 100 .dwg files.

Gallery



Traditional

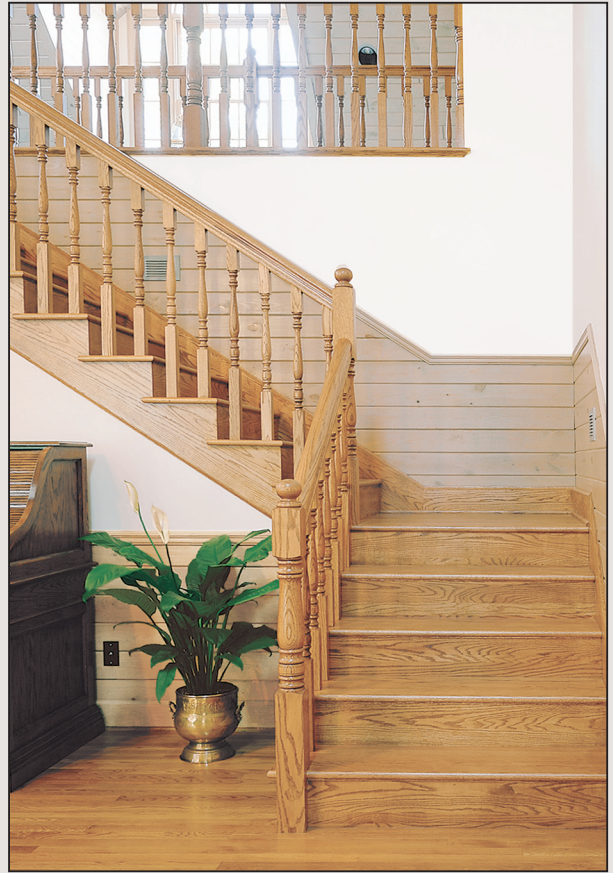

Hampton



Sheraton



Wrought Iron

Installation Manual

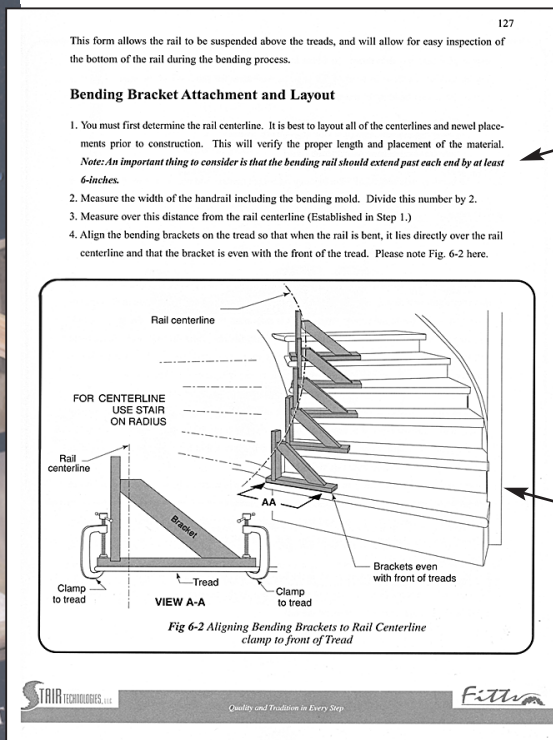
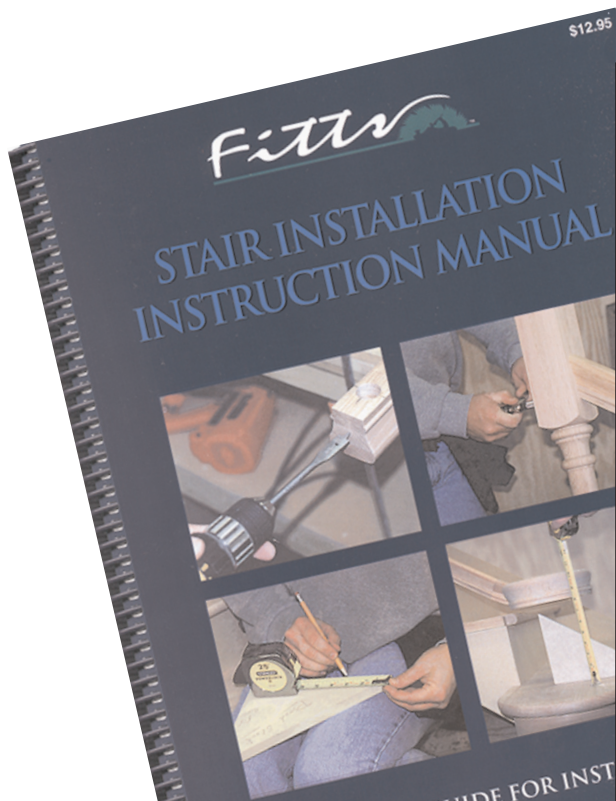

Easy to Read

Heavy Duty 8" x 10" Construction

Clean Illustrations

- 8 x 10 Spiral Bound **Heavy Duty Construction** no more squinting with pocket sized manuals
- **Easy to read** — Step by Step Instructions — no more follow by numbers
- **Cleanly Illustrated** — No Nonsense Illustrations
- **Calculation Boxes** — Alleviate the guesswork

The Fitts Industries, Inc. **Stair Installation Instruction Manual**© is the most comprehensive guide to stair building on the market. This 160 page instruction manual has over 150 images depicting:

- **The Design and Layout of the Stair**
- **Installing Skirts, Treads & Risers**
- **Installing Post-to-Post Balustrade**
- **Installing Over-the-Post Balustrade**
- **Bending Handrail Installation**
- **Wrought Iron Balustrade Installation & More...**

Empower yourself with the knowledge of stair building.

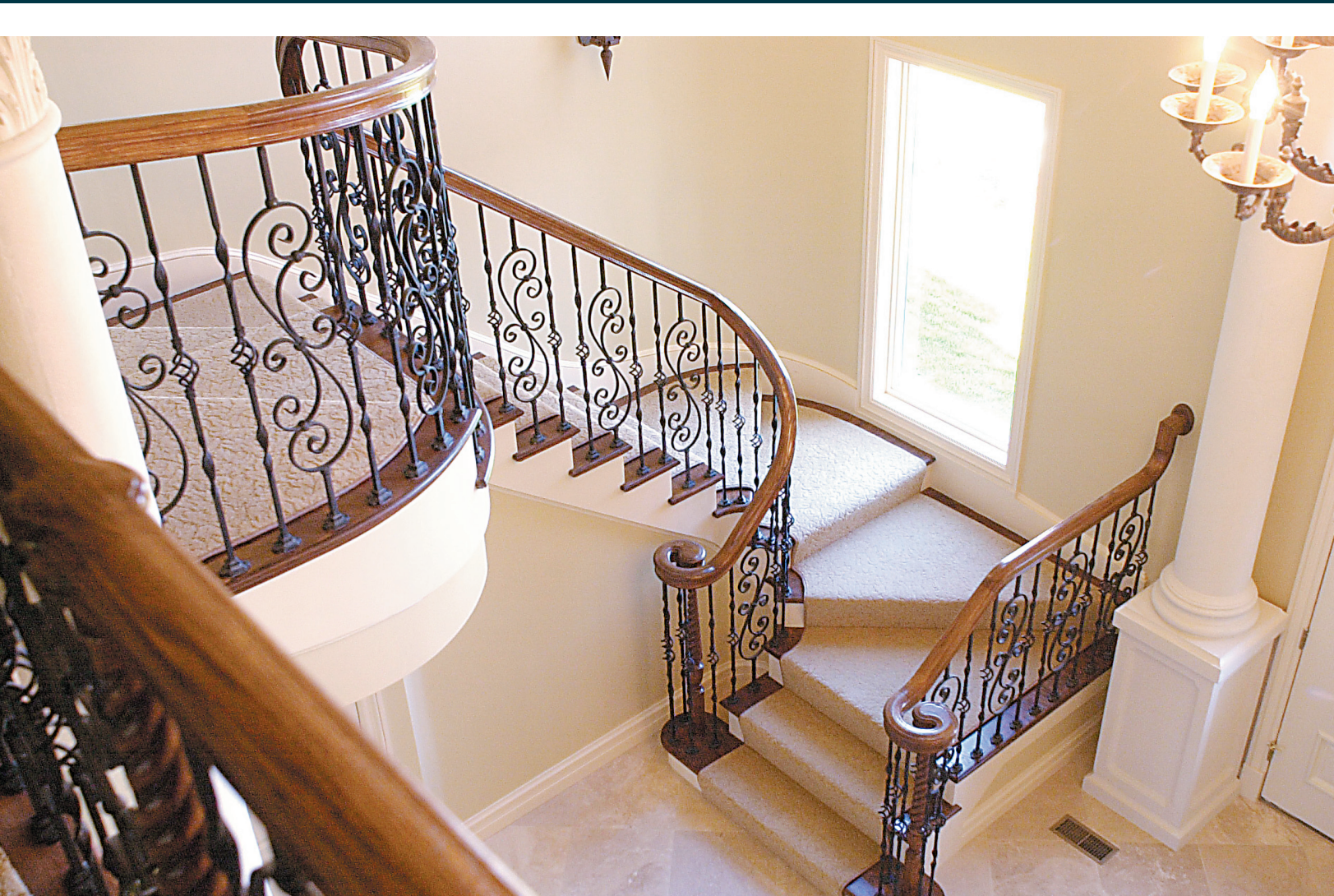

Fitts 

Manufacturers of Quality Stair Parts

Fitts Industries, Inc. • Western Division
5640 South Durango • Tacoma, WA 98409

Ph: 253.474.2923

Fx: 253.474.0408

©2005 Fitts Industries, Inc.
www.fitts.com

Wood Species



Red Oak



Maple



Soft Maple



Poplar



Knotty Pine



Cherry



Hemlock



Alder

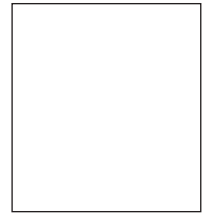

Prime

We Manufacture Non - Stock Product in:



Mahogany



Beech



Hickory

*Please Note our Price Books for Pricing and Availability